

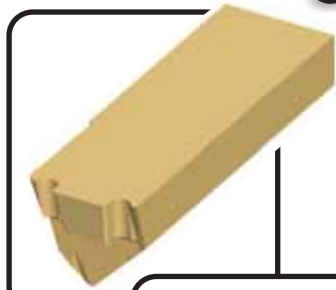

**Year after Year, Large and Small Companies
Call Horizon FIRST for their
Threading, Grooving & Finishing Needs!**

Just Look at Our Strengths!



■ **EXPERT, ORIGINAL TOOL DESIGNS BUILT WITHIN DAYS, NOT MONTHS!**

■ Call Horizon for **TIME-CRITICAL PRODUCTION** on **"SPECIALS"** and **SMALL QUANTITY RUNS**. We're fast, precise and cost effective!



■ The aerospace, automotive and medical industries, electronics companies, manufacturing firms, and more have called Horizon a knowledgeable, dependable, **TRUSTED VENDOR**, since 1988.

■ *Our standard defined:* **PREMIUM QUALITY, PRECISION-ENGINEERED, CNC GROUND INSERTS** that **EXCEED** industry standard tolerances.

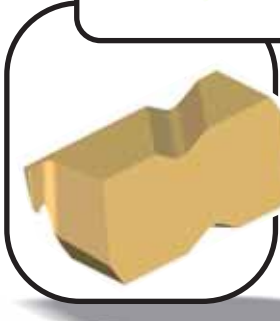

■ With over 100 years combined experience, we're experts at producing inserts for **STAINLESS STEEL, TITANIUM**, and other tough-to-machine **ALLOYS**, as well as inserts designed for soft materials and plastics.

■ **DEEPER DEPTHS OF CUT!** Our standard notch style grooving inserts have longer back distances than our competition. The "E" dimension in our catalog is the **ACTUAL** depth of cut!

■ In addition to our catalog listings, **Horizon stocks hundreds of hard-to-find widths at reasonable prices**. Our inventory includes groovers as small as .020 wide and .010 full-nose radii. Need smaller radii for turning? We stock from .002 to .008 in the most popular CNC styles. **GIVE US A CALL** for pricing and availability **when you need MORE than industry standards**. In many cases, we'll have just what you need.

Call Horizon Today! We're the Industry's Leading Problem-Solver!

TABLE OF CONTENTS

ABOUT HORIZON CARBIDE _____ PAGE 1

TABLE OF CONTENTS _____ PAGES 2 - 3

FEATURED PRODUCTS _____ PAGE 4

HORIZON GRADES _____ 5

NOTCH STYLE GROOVING INSERTS* 6 - 14

HG – Grooving _____	6 - 8
HG-RK/LK – Chip Curler Grooving _____	8 - 9
HGD – Deep Grooving _____	9
HGD-RK/LK – Chip Curler Deep Grooving _____	9 - 10
HGP – Positive Rake Grooving _____	10
HR – Full Nose Radius Grooving _____	11
HRP – Positive Rake Full Nose Radius Grooving _____	12
HRD – Full Nose Radius Deep Grooving _____	12
HF – Face Grooving _____	13
HF-RK/LK – Chip Curler Face Grooving _____	13
HFD – Deep Grooving _____	13
HV – Poly-V Grooving _____	14
HU – Undercutting _____	14
HB – Precision Ground Blanks _____	14
HBD – Deep Precision Ground Blanks _____	14

ANSI STANDARD DOGBONE & ON-EDGE GROOVERS _____ 15 - 17

VDB – Dogbone _____	15
VDB-C – Chip Curler Dogbone _____	15
VDB-R – Full Nose Radius Dogbone _____	15
GC – Dogbone _____	15
TNMA - TPMA - TNMC - TPMC – On-Edge _____	16 - 17

NOTCH STYLE THREADING INSERTS* 18 - 20

HT – Threading _____	18
HTP – Positive Rake Threading _____	18
HTF – Close Shoulder Threading _____	18

NOTCH STYLE THREADING INSERTS 18 - 20

HTK – Close Shoulder Positive Rake _____	18
HT-C – Coarse Pitch .015R _____	19
HTP-C – Positive Rake Coarse Pitch .015R _____	19
HTC – 60° Cresting Style Full Profile _____	19
HDC – NPT Cresting Style Full Profile _____	19
HA – Acme _____	20
HAS – Stub Acme _____	20

LAYDOWN THREADING INSERTS 21 - 23

11NR, 16ER/NR, 22ER/NR, 27ER/NR – 60° Partial Profile _____	21
16ER/NR, 22ER/NR – 60° UN Full Profile _____	21
16ER UNJ – Full Profile UNJ Controlled Root _____	22
16ER/NR NPT – Full Profile NPT _____	22
16ER/NR, 22ER/NR ACME – Full Profile Acme _____	22
16ER/NR, 22ER/NR ST-ACME – Full Profile Stub Acme _____	23
16ER/NR ISO – Full Profile ISO Metric _____	23

ON-EDGE THREADING INSERTS 24

TNMA, TPMA, TNMC, TPMC – On-Edge _____	24
---	----

ANSI - ISO TURNING INSERTS 25 - 29

CFG, CPG, SPG, TD 6P, TP 4x, TP 6x, TFG, TPG, T221P, T321P – Turning _____	25
CCGT, CPGT – Screw-On _____	26
DCGT, DPGT – Screw-On _____	26
VBGT, VCGT – Screw-On _____	26
CCGT-25P – High Positive Screw-On _____	27
DCGT-25P – High Positive Screw-On _____	27
VCGT-25P – High Positive Screw-On _____	27
CNGP 43x-K – 80° Pos/Neg _____	28
CNGG 43x – 80° Positive Chipbreaker _____	28
DNGP 43x-K – 55° Double-Sided Pos/Neg _____	28
VNGP 33x-K – 35° Double-Sided Light Finishing _____	28

TABLE OF CONTENTS

ANSI - ISO TURNING INSERTS 28 - 29

VNGP 33x-D – 35° Double-Sided General Purpose	28
WNGP 43x-K – Trigon Pos/Neg	28
CNMA 43x – 80° Flat Top for Hard Materials	29
CNMG 432GP – 80° for Stainless & Hi-Temp Alloys	29
CNMG 432HT – 80° for Light Roughing	29
DNMG 431, 432 – 55° for Light Roughing	29
VNMG 331, 332 – 35° for Light Roughing	29
WNMG 432GP – Trigon for Stainless & Hi-Temp Alloys	29

NOTCH STYLE PROFILING INSERTS 30

HPR/HPL 5x, 13x, 33x – 55° Notch Style Profiling	30
DPGR 43x – 55° Profiling	30
VPGR 33x – 35° Profiling	30

TOOL HOLDERS & BORING BARS 31 - 33

TSR, TSL – Notch Style OD Tool Holders	31
TER, TEL – 90° Face Grooving Tool Holders	32
C-TER, C-TEL – Carbide Shank Boring Bars	32
A-TER, A-TEL – Steel Shank Boring Bars with Coolant Holes	33

SOLID CARBIDE THREAD MILLS 34 - 41

NPT, NPTF Internal - External	34
NPSM, NPSF - BSPT Thread Mills	35
BSP, ISO Thread Mills	36
ISO Metric, UN - UNJ External	37
ISO Metric Internal T2-T3 Long Length	38
UN Internal Std Length	39
UN Internal Threads T3 Extra Long	40
UN Internal Threads T2 Long Length	41

TECHNICAL INFORMATION 42 - 54

SPEEDS & FEEDS	42
THREADING INFORMATION	43
FACE GROOVING INFORMATION	44
DOVETAIL FACE GROOVING	45
COMPETITIVE INSERT CONVERSIONS*	46
COMPETITIVE INSERT INFORMATION	47
COMPETITIVE GRADE COMPARISONS	48
CARBIDE GRADE INFORMATION	49
TECHNICAL INFO - TROUBLESHOOTING	50
GENERAL INFORMATION	51
SPECIALS	52
QUICK MODIFICATIONS	53
SPECIAL TOOL REQUEST FORM	54
PROGRAMMING REQUEST FORM	55
Thread Milling Speeds And Feeds	56



2404 SOUTH INDUSTRIAL PARK AVENUE
TEMPE, ARIZONA 85282

Featured Products from Horizon

Our goal at HORIZON is to create precision engineered products that meet our customers' changing needs. We invite you to check out our latest products, listed below.

Carbide Grades

C23 Premium Uncoated MicroGrain C2-C3 Grades

For aluminum, copper and plastics!

323 TiAlN Coated C2-C3/C7 Grade

Your first choice for threading, grooving and finishing stainless steel, titanium, and high temp alloys. They also work well at medium to high speeds and lighter feeds in most other materials as well.

356 TiAlN Coated C5-C6 Steel Cutting Grade



This new addition to our line is excellent for threading and grooving carbon and alloy steels at moderate speeds and light to medium feeds. It also works well with stainless steels, especially the 400-series stainless.

RK-LK Chip Curler Inserts

Precision ground (not molded!) for the finest chip flow in the industry. Horizon's RK-LK Chip Curler Inserts are designed to lower cutting forces while reducing edge build-up in stainless, titanium and Inconel.[®] They also work well at lighter feeds in any gummy material and can be used at high feeds in aluminum, copper and plastic. See Pages 8, 9, 10, 13, and 15.



NEW! Hard-to-Find HGD Size 2 Deep Grooving Inserts

Now available at Horizon in four standard widths: .047, .062, .094, and .125 - ID or OD up to .200 depth of cut. Ideal for screw machines and smaller diameter boring holes.

We stock these in five grades: C23, 310, 323FG, 310FG, 310 and 323 for fast delivery! See Page 9.



NEW! Size 1 ID Threading and Grooving Inserts

Extra small groovers in four widths: .031, .047, .062, and .094. We stock these in three tough MicroGrain Carbide grades: C10, 310FG, and 310. See Page 6.



NEW! Horizon Grade C23J Turning Inserts for Aluminum, Copper & Plastic

Precision ground C23J inserts - sharp edges and polished chip breakers reduce built-up edge and improve chip flow. Available in CNGP, DNGP, VNGP, and WNGP styles from .004R to .031R. See Pages 25 & 27.



ALL NEW & TESTED for Exceptional Performance: Horizon Roughing Inserts!



CNMG - WNMG GP Inserts – Excellent for light to medium roughing in tough-to-machine alloys and 300-series stainless.

VNMG - CNMG - DNMG HT – Light roughing for high temperature alloys and titanium. See Page 28.



HORIZON UNCOATED CARBIDE GRADES				
Grade	ANSI	ISO	Color	Description
C10	C1 \ C5	K40 / P40	Gray	Tough Grade for small diameters or severe applications at low speeds.
C20	C2	K20 - K25	Gray	Uncoated Grade for Non-Ferrous materials. <i>Non-Stock</i>
C23	C2-C3	K10-K20 / M20	Gray	Premium C2-C3 Grade for Non-Ferrous Metals, Plastics and Non-Metals.
C23J	C2-C3	K10-K20 / M20	Gray	Grade C23 Inserts with Polished Chipbreakers for Aluminum, Copper and Plastics. The Polished Tops and Sharp Edges help prevent Chip Build-up.
C56	C5-C6	P20-P30	Gray	Uncoated Grade for Carbon and Alloy Steels at medium speeds. <i>Non-Stock</i>
HCC	C4 \ C7	P10 / K05	Silver	Ceramet Grade for finishing at high speeds and light feed rates. <i>Non-Stock</i>

HORIZON COATED CARBIDE GRADES				
Grade	ANSI	ISO	Color	Description
310FG	C1-C2 / C5	K25-K40 / P50	Gold	Tough PVD TIN Coated Micrograin Grade for Low to Medium Speeds. Good for small diameter work under 1" and Screw Machine applications.
320FG	C2-C3	K15-K25 / M20	Gold	PVD TIN Coated C2 Grade for special applications. <i>Non-Stock</i>
323FG	C2-C3 / C6	K10-K20 M15-M20	Gold	PVD TIN Coated C2-C3 Grade for Threading, Grooving and Finishing. Use TiALN coated Grades 310, 323 or 323F for Higher Performance & Longer Tool Life in 300 Series Stainless Steel, Titanium and High Temp Alloys
356FG	C5-C6	P20-P30	Gold	PVD TIN Coated C5-C6 Grade for Threading and Grooving Carbon & Alloy Steels. Use 356, 323 or 323F for Higher Performance and Longer Tool Life.
223	C2-C3	K10-K25 / M20	Blue-Gray	PVD TiCN Coated C2-C3 Grade for special applications. <i>Non-Stock</i>
256	C5-C6	P20-P30	Blue-Gray	PVD TiCN Coated C5-C6 Grade for special applications. <i>Non-Stock</i>
310	C1-C2 C5-C6	K25-K40 M25-M35 P35-P50	Bronze	Tough PVD TiALN Coated Micrograin Grade Designed for Face Grooving. Also for Threading & Grooving smaller parts under 1" diameter at low to medium speeds. (Not recommended for Copper or Aluminum)
323	C2-C3 C6-C7	K10-K25 M15-M25 P15-P25	Bronze	High Performance PVD TiALN Coated Grade. First choice for Threading Grooving and Finishing 300 Series Stainless, High Temp Alloys. Works well on Iron and Steel at Medium Speeds and Light Feed Rates. (Not recommended for Copper or Aluminum)
323F	C2-C3 C6-C7	K10-K25 M15-M25 P15-P25	Gray-Black	PVD TiALN Coated Grade similar in performance to 323. Smooth coating can be used on Aluminum without galling. Most Laydown Threading and High Positive Aluminum Screw Down Inserts are available in Grade 323F. All other Inserts in this Grade are <i>Limited-Stock</i> items.
320AP	C2-C3	K20	Grey	PVD TiALN, AlOxide Coated Special enhanced version of Grade C23 For Cast Iron, Grey, and Ductile. <i>Non-Stock</i>
356	C5-C6	P20-P30	Bronze	PVD TiALN Coated Grade. 1st Choice for General Purpose use on Steels.
423	C2-C3 / C6	K10-K20 / P15	Gold	CVD TIN Coated Non-Ferrous Grade for special applications. <i>Non-Stock</i>
456	-C6	P20-P30	Gold	CVD TIN Coated Steel cutting Grade for special applications. <i>Non-Stock</i>
523	C2-C3 / C7	K10-K20 / P15	Gold	CVD Multi-Coated Steel cutting Grade for special applications. <i>Non-Stock</i>
556	C5-C6	P20-P30	Gold	CVD Multi-Coated Steel cutting Grade for special applications. <i>Non-Stock</i>
623	C3-C4	K10-K15	Black	CVD Aluminum Oxide coated for Cast Iron & Hard Materials. <i>Non-Stock</i>

BOLD = Standard Horizon Grades *Non-Stock = Non-Stock Grades or Limited Stock Items - Call for availability*

GROOVING INSERTS

6

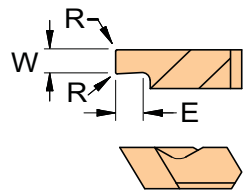
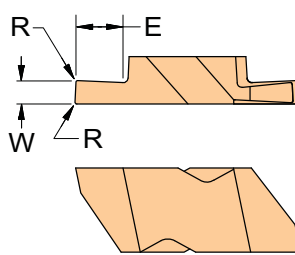
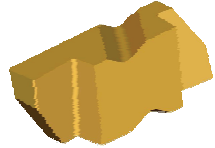
Style:	Insert Description		Dimensions			Grades				
HG Size 1 ID Grooving	Right Hand	Left Hand	W	R	E	C10	310FG	310		
 <p>Left Hand Shown</p>	NA		.031	.0035	.050	NA	NA	NA		
		HG 1031L		± .0015		S	S	S		
	NA		.047	.0035	.075	NA	NA	NA		
		HG 1047L		± .0015		S	S	S		
	NA		.062	.0035	.075	NA	NA	NA		
		HG 1062L		±.0015		S	S	S		
	NA		.094	.0035	.075	NA	NA	NA		
	HG 1094L		± .0015		S	S	S			
Style:	Insert Description		Dimensions			Grades				
HG Size 2	Right Hand	Left Hand	W	R	E	C23	323FG	356FG	323	356
 <p>Right Hand Shown</p> <p>E Dimension is Maximum Depth of Cut</p> <p>Use RH Inserts with RH External Tool Holders</p> <p>Use LH Inserts with RH Internal Boring Bars</p> <p>For Tool Holder Information See Pages 31- 33</p>  <p>Left Hand Insert</p>	HG 2031R		.031	.0035	.055	S	S	S	LS	S
		HG 2031L		± .0015		S	S	LS	LS	LS
	HG 2039R		.039	.0035	.055	S	S	LS	LS	LS
		HG 2039L		± .0015		S	LS	LS	LS	LS
	HG 2041R		.041	.0035	.055	S	S	S	LS	S
		HG 2041L		± .0015		S	S	S	LS	S
	HG 2047R		.047	.0035	.080	S	S	S	LS	S
		HG 2047L		± .0015		S	S	LS	LS	LS
	HG 2055R		.055	.0035	.080	S	S	S	LS	S
		HG 2055L		± .0015		LS	LS	LS	LS	LS
	HG 2058R		.058	.0075	.080	S	S	LS	LS	LS
		HG 2058L		± .0025		S	S	LS	LS	LS
	HG 2062R		.062	.0075	.115	S	S	S	LS	S
		HG 2062L		± .0025		S	S	S	LS	S
	HG 2070R		.070	.0075	.115	S	S	LS	LS	LS
		HG 2070L		± .0025		S	S	LS	LS	LS
	HG 2079R		.079	.0075	.115	LS	LS	LS	LS	LS
		HG 2079L		± .0025		LS	LS	LS	LS	LS
	HG 2094R		.094	.0075	.115	S	S	S	LS	S
		HG 2094L		± .0025		S	S	S	LS	S
HG 2118R		.118	.0075	.115	S	S	LS	LS	LS	
	HG 2118L		± .0025		S	LS	LS	LS	LS	
HG 2125R		.125	.0075	.115	S	S	S	LS	S	
	HG 2125L		± .0025		S	S	S	LS	S	
HG 2140R		.140	.0075	.115	S	S	S	LS	S	
	HG 2140L		± .0025		S	LS	LS	LS	LS	

S = Stock Standard LS = Limited Stock or Non-Stock - Call for Availability

Metric Sizes and Modified or Full Special Inserts Available on Request

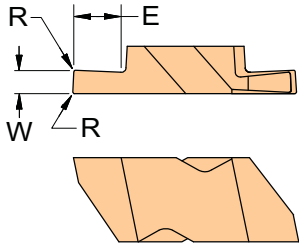
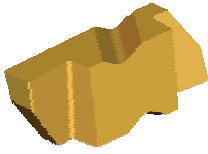
Style:	Insert Description		Dimensions			Grades				
	Right Hand	Left Hand	W	R	E	C23	323FG	356FG	323	356
 <p>Right Hand Shown</p> <p>E Dimension is Maximum Depth of Cut</p> <p>Use RH Inserts with RH External Tool Holders</p> <p>Use LH Inserts with RH Internal Boring Bars</p> <p>For Tool Holder Information See Pages 31- 33</p> <p>Metric Sizes & Full Special Inserts Available on Request</p>  <p>Left Hand Insert</p>	HG 3020R		.020	.0035	.055	S	S	LS	LS	LS
		HG 3020L		± .0015		LS	LS	LS	LS	LS
	HG 3031R		.031	.0035	.055	S	S	LS	LS	LS
		HG 3031L		± .0015		S	S	LS	LS	LS
	HG 3039R		.039	.0035	.055	S	S	LS	LS	LS
		HG 3039L		± .0015		S	LS	LS	LS	LS
	HG 3047R		.047	.0035	.080	S	S	S	LS	S
		HG 3047L		± .0015		S	S	S	LS	S
	HG 3062R		.062	.0075	.125	S	S	S	LS	S
		HG 3062L		± .0025		S	S	S	LS	S
	HG 3072R		.072	.0075	.125	S	S	S	LS	S
		HG 3072L		± .0025		LS	LS	LS	LS	LS
	HG 3078R		.078	.0075	.125	S	S	S	LS	S
		HG 3078L		± .0025		S	S	LS	LS	LS
	HG 3081R		.081	.0075	.125	S	S	LS	LS	LS
		HG 3081L		± .0025		LS	LS	LS	LS	LS
	HG 3082R		.082	.0075	.125	S	S	LS	LS	LS
		HG 3082L		± .0025		LS	LS	LS	LS	LS
	HG 3088R		.088	.0075	.125	S	S	LS	LS	LS
		HG 3088L		± .0025		LS	LS	LS	LS	LS
	HG 3094R		.094	.0075	.192	S	S	S	LS	S
		HG 3094L		± .0025		S	S	S	LS	S
	HG 3097R		.097	.0075	.192	S	S	LS	LS	LS
		HG 3097L		± .0025		S	S	LS	LS	LS
	HG 3105R		.105	.0075	.192	S	S	LS	LS	LS
		HG 3105L		± .0025		S	S	LS	LS	LS
	HG 3110R		.110	.0075	.192	S	S	S	LS	S
		HG 3110L		± .0025		S	S	LS	LS	LS
	HG 3118R		.118	.0075	.192	S	S	LS	LS	LS
		HG 3118L		± .0025		S	LS	LS	LS	LS
	HG 3125R		.125	.0075	.205	S	S	S	LS	S
		HG 3125L		± .0025		S	S	LS	LS	LS
HG 3140R		.140	.0075	.205	LS	LS	LS	LS	LS	
	HG 3140L		± .0025		LS	LS	LS	LS	LS	
HG 3142R		.142	.0125	.205	S	S	S	LS	S	
	HG 3142L		± .0025		LS	LS	LS	LS	LS	
HG 3156R		.156	.0125	.205	S	S	S	LS	S	
	HG 3156L		± .0025		S	S	S	LS	S	
HG 3158R		.158	.0125	.205	S	S	LS	LS	LS	
	HG 3158L		± .0025		LS	LS	LS	LS	LS	

S = Stock Standard

LS = Limited Stock or Non-Stock - Call for Availability

GROOVING INSERTS

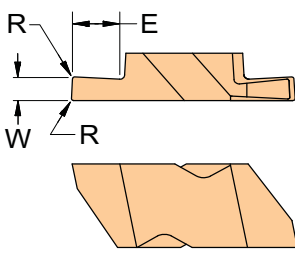
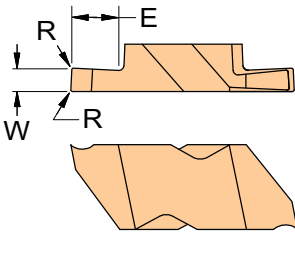
Style:	Insert Description		Dimensions			Grades				
HG Size 3 & 4	Right Hand	Left Hand	W	R	E	C23	323FG	356FG	323	356
 <p>Right Hand Shown</p> <p>E Dimension is Maximum Depth of Cut</p> <p>For Tool Holder Information See Pages 31- 33</p>	HG 3178R		.178	.0225	.205	LS	LS	LS	LS	LS
		HG 3178L		± .0025		LS	LS	LS	LS	LS
	HG 3185R		.185	.0225	.205	S	S	LS	LS	S
		HG 3185L		± .0025		LS	LS	LS	LS	LS
	HG 3189R		.189	.0225	.205	S	S	LS	LS	S
		HG 3189L		± .0025		S	S	LS	LS	LS
	HG 4093R		.093	.0075	.255	S	S	LS	LS	LS
		HG 4093L		± .0025		S	LS	LS	LS	LS
	HG 4125R		.125	.0075	.255	S	S	LS	LS	LS
		HG 4125L		± .0025		S	LS	LS	LS	LS
	HG 4189R		.189	.0225	.255	S	S	S	LS	S
		HG 4189L		± .0025		S	S	S	LS	S
	HG 4219R		.219	.0225	.255	S	LS	LS	LS	LS
		HG 4219L		± .0025		LS	LS	LS	LS	LS
HG 4250R		.250	.0225	.255	S	S	LS	LS	LS	
	HG 4250L		± .0025		S	LS	LS	LS	LS	
Style:	Insert Description		Dimensions			Grades				
HG-RK/LK Chip Curler	Right Hand	Left Hand	W	R	E	C23	323FG	356FG	323	356
 <p>Right Hand Shown</p> <p>Ground-in Chip Curlers With 15° - 18° Positive Rake.</p> <p>Lower Cutting Pressures and Reduced Edge Build-up.</p> <p>Use Lighter Feeds on Tough Materials - .0005 - .003 / Rev.</p> <p>Run Aluminum, Copper and Plastics at Higher Feed Rates.</p>	HG 2031RK		.031	.0035	.055	S	S	LS	LS	LS
		HG 2031LK		± .0015		S	S	LS	LS	LS
	HG 2041RK		.041	.0035	.055	S	S	LS	LS	LS
		HG 2041LK		± .0015		S	S	LS	LS	LS
	HG 2062RK		.062	.0075	.115	S	S	LS	LS	LS
		HG 2062LK		± .0025		S	S	LS	LS	LS
	HG 2125RK		.125	.0075	.115	S	S	LS	LS	LS
		HG 2125LK		± .0025		S	S	LS	LS	LS
	HG 3047RK		.047	.0035	.080	S	S	LS	LS	LS
		HG 3047LK		± .0015		S	S	LS	LS	LS
	HG 3062RK		.062	.0075	.125	S	S	S	LS	S
		HG 3062LK		± .0025		S	S	S	LS	S
	HG 3072RK		.072	.0075	.125	S	S	LS	LS	LS
		HG 3072LK		± .0025		S	S	LS	LS	LS
HG 3088RK		.088	.0075	.125	S	S	LS	LS	LS	
	HG 3088LK		± .0025		S	LS	LS	LS	LS	
HG 3094RK		.094	.0075	.192	S	S	S	LS	S	
	HG 3094LK		± .0025		S	S	LS	LS	S	
HG 3125RK		.125	.0075	.205	S	S	S	LS	S	
	HG 3125LK		± .0025		S	LS	LS	LS	S	
HG 3156RK		.156	.0125	.205	S	S	LS	LS	LS	
	HG 3156LK		± .0025		LS	LS	LS	LS	LS	

S = Stock Standard LS = Limited Stock or Non-Stock - Call for Availability

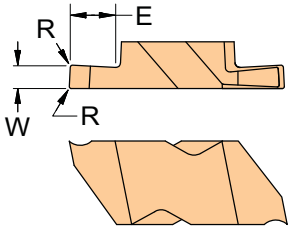
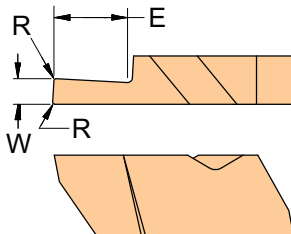
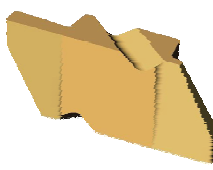
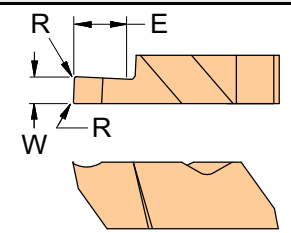

Style:	Insert Description		Dimensions			Grades				
 <p>Right Hand Shown</p>	Right Hand	Left Hand	W	R	E	C23	323FG	356FG	323	356
	HG 4125RK		.125	.0075	.255	S	S	LS	LS	LS
		HG 4125LK		± .0025		S	LS	LS	LS	LS
	HG 4189RK		.189	.0225	.255	S	S	LS	LS	LS
		HG 4189LK		± .0025		S	S	LS	LS	LS
	HG 4250RK		.250	.0225	.255	S	S	S	LS	S
		HG 4250LK		± .0025		LS	LS	LS	LS	LS
Style:	Insert Description		Dimensions			Grades				
HGD Size 2, 3 & 4 Deep Grooving	Right Hand	Left Hand	W	R	E	C23	310FG	323FG	310	323
 <p>Right Hand Shown</p> <p>* HGD 3062R/L * HGD 4125R/L</p>  <p>Double Ended Deep Groovers Have Same Overall Lengths as Standard Size 3 and 4 Inserts</p>	HGD 2047R		.047	.004	.185	S	LS	S	LS	LS
		HGD 2047L		± .001		S	LS	S	LS	LS
	HGD 2062R		.062	.004	.200	S	LS	S	LS	LS
		HGD 2062L		± .001		S	LS	S	LS	LS
	HGD 2094R		.094	.004	.200	S	LS	S	LS	LS
		HGD 2094L		± .001		S	LS	S	LS	LS
	HGD 2125R		.125	.004	.200	S	LS	S	LS	LS
		HGD 2125L		± .001		S	LS	S	LS	LS
	HGD 3062R*		.062	.0075	.192	S	LS	S	LS	LS
		HGD 3062L*		± .0025		S	LS	S	LS	LS
	HGD 3094R		.094	.0075	.255	S	LS	S	LS	LS
		HGD 3094L		± .0025		S	LS	S	LS	LS
	HGD 3125R		.125	.0075	.255	S	LS	S	LS	LS
		HGD 3125L		± .0025		S	LS	S	LS	LS
	HGD 3189R		.189	.0225	.255	S	LS	S	LS	LS
		HGD 3189L		± .0025		LS	LS	LS	LS	LS
	HGD 4125R*		.125	.0075	.300	S	LS	S	LS	LS
		HGD 4125L*		± .0025		S	LS	S	LS	LS
	HGD 4189R		.189	.0225	.505	S	LS	S	LS	LS
		HGD 4189L		± .0025		S	LS	S	LS	LS
HGD 4250R		.250	.0225	.505	LS	LS	LS	LS	LS	
	HGD 4250L		± .0025		LS	LS	LS	LS	LS	
Style:	Insert Description		Dimensions			Grades				
HGD-RK/LK Size 2	Right Hand	Left Hand	W	R	E	C23	310FG	323FG	310	323
 <p>Size 2 Right Hand Shown</p>	HGD 2047RK		.047	.004	.185	S	LS	S	LS	LS
		HGD 2047LK		± .001		S	LS	S	LS	LS
	HGD 2062RK		.062	.004	.200	S	LS	S	LS	LS
		HGD 2062LK		± .001		S	LS	S	LS	LS
	HGD 2094RK		.094	.004	.200	S	LS	S	LS	LS
		HGD 2094LK		± .001		S	LS	S	LS	LS
	HGD 2125RK		.125	.004	.200	S	LS	S	LS	LS
	HGD 2125LK		± .001		S	LS	S	LS	LS	

S = Stock Standard LS = Limited Stock or Non-Stock - Call for Availability

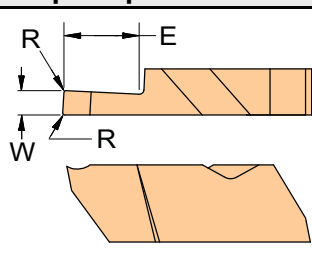
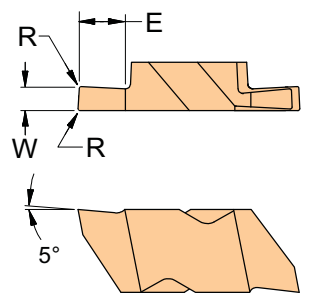
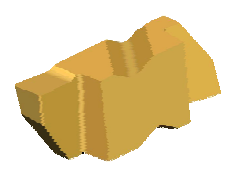
GROOVING INSERTS

Style:	Insert Description		Dimensions			Grades				
HGD-RK/LK 3 & 4 Deep Chip Curler	Right Hand	Left Hand	W	R	E	C23	310FG	323FG	310	323
 <p>Right Hand Shown</p> <p>*Double Ended Inserts With 2 Cutting Edges</p>	HGD 3062RK*		.062	.0075	.192	S	LS	LS	SL	LS
		HGD 3062LK*		± .0025		S	LS	S	LS	LS
	HGD 3094RK		.094	.0075	.255	S	LS	S	LS	LS
		HGD 3094LK		± .0025		S	LS	S	LS	LS
	HGD 3125RK		.125	.0075	.255	S	LS	S	LS	LS
		HGD 3125LK		± .0025		S	LS	S	LS	LS
	HGD 4125RK*		.125	.0075	.300	S	LS	S	LS	LS
		HGD 4125LK*		± .0025		S	LS	S	LS	LS
HGD 4250RK		.250	.0225	.505	S	LS	S	LS	LS	
	HGD 4250LK		± .0025		S	LS	S	LS	LS	
Style:	Insert Description		Dimensions			Grades				
HGP 5° Positive Rake	Right Hand	Left Hand	W	R	E	C23	323FG	356FG	323	356
 <p>Right Hand Shown</p> <p>E Dimension is Maximum Depth of Cut</p> <p>Use RH Inserts with RH External Tool Holders</p> <p>Use LH Inserts with RH Internal Boring Bars</p> <p>For Tool Holder Information See Pages 31- 33</p>  <p>Left Hand Insert</p>	HGP 2031R		.031	.0035	.055	S	S	S	LS	S
		HGP 2031L		± .0015		S	S	S	LS	S
	HGP 2041R		.041	.0035	.055	S	S	LS	LS	LS
		HGP 2041L		± .0015		S	S	S	LS	S
	HGP 2047R		.047	.0035	.080	LS	LS	LS	LS	LS
		HGP 2047L		± .0015		S	S	S	LS	S
	HGP 2062R		.062	.0075	.115	S	S	S	LS	S
		HGP 2062L		± .0025		S	S	S	LS	S
	HGP 2094R		.094	.0075	.115	S	S	LS	LS	LS
		HGP 2094L		± .0025		S	S	LS	LS	LS
	HGP 2125R		.125	.0075	.115	S	S	LS	LS	LS
		HGP 2125L		± .0025		S	S	LS	LS	LS
	HGP 3031R		.031	.0035	.055	S	S	LS	LS	LS
		HGP 3031L		± .0015		S	S	LS	LS	LS
	HGP 3047R		.047	.0035	.080	S	S	LS	LS	S
		HGP 3047L		± .0015		S	S	LS	LS	LS
	HGP 3062R		.062	.0075	.125	S	S	LS	LS	S
		HGP 3062L		± .0025		S	S	S	LS	S
	HGP 3088R		.088	.0075	.125	S	S	LS	LS	LS
		HGP 3088L		± .0025		S	S	LS	LS	LS
	HGP 3092R		.092	.0075	.192	S	S	LS	LS	LS
		HGP 3092L		± .0025		S	S	LS	LS	LS
	HGP 3094R		.094	.0075	.192	S	S	S	LS	S
		HGP 3094L		± .0025		S	S	LS	LS	LS
	HGP 3125R		.125	.0075	.205	S	S	LS	LS	LS
		HGP 3125L		± .0025		S	S	LS	LS	LS
	HGP 3156R		.156	.0075	.205	S	S	S	LS	S
		HGP 3156L		± .0025		S	S	LS	LS	LS
HGP 3189R		.189	.0225	.205	S	S	LS	LS	LS	
	HGP 3189L		± .0025		S	S	LS	LS	LS	
HGP 4189R		.189	.0225	.255	S	LS	LS	LS	LS	
	HGP 4189L		± .0025		S	S	LS	LS	LS	
HGP 4250R		.250	.0225	.255	LS	LS	LS	LS	LS	
	HGP 4250L		± .0025		LS	LS	LS	LS	LS	

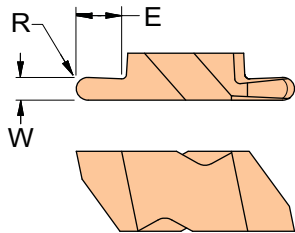
S = Stock Standard LS = Limited Stock or Non-Stock - Call for Availability

Style:	Insert Description		Dimensions			Grades					
	Right Hand	Left Hand	W	R	E	C23	323FG	356FG	323	356	
 <p>Right Hand Shown</p> <p>E Dimension is Maximum Depth of Cut</p> <p>Use RH Inserts with RH External Tool Holders</p> <p>Use LH Inserts with RH Internal Boring Bars</p> <p>For Tool Holder Information See Pages 31- 33</p>  <p>Left Hand Insert</p>	HR 2015R		.030	.015	.055	S	S	LS	LS	LS	
		HR 2015L		.030	.015	.055	S	S	LS	LS	LS
		HR 2031R		.062	.031	.115	S	S	LS	LS	LS
		HR 2031L					LS	S	LS	LS	LS
		HR 2047R		.094	.047	.115	S	S	LS	LS	LS
		HR 2047L					S	S	LS	LS	LS
		HR 2062R		.125	0.062	.115	S	S	LS	LS	LS
		HR 2062L					S	S	LS	LS	LS
		HR 3010R		.020	.010	.055	S	S	LS	LS	LS
		HR 3010L					LS	LS	LS	LS	LS
		HR 3015R		.030	.015	.055	S	LS	S	LS	S
		HR 3015L					S	S	LS	LS	LS
		HR 3020R		.040	.020	.055	S	S	LS	LS	LS
		HR 3020L					S	LS	LS	LS	LS
		HR 3026R		.052	.026	.055	S	S	LS	LS	LS
		HR 3026L					S	LS	LS	LS	LS
		HR 3031R		.062	.031	.130	S	S	S	LS	S
		HR 3031L					S	S	S	LS	S
		HR 3039R		.078	.039	.130	S	S	LS	S	LS
		HR 3039L					S	LS	LS	LS	LS
		HR 3047R		.094	.047	.185	S	LS	S	LS	S
		HR 3047L					S	S	S	LS	S
		HR 3062R		.125	.062	.185	S	S	S	LS	S
		HR 3062L					S	S	LS	LS	S
		HR 3078R		.156	.078	.185	S	S	S	LS	S
		HR 3078L					LS	LS	S	LS	S
		HR 3094R		.188	.094	.185	S	S	S	LS	S
		HR 3094L					S	S	LS	LS	LS
		HR 3125R		.250	.125	.192	S	S	S	LS	S
		HR 3125L					S	S	LS	LS	LS
	HR 4062R		.125	.062	.255	S	S	S	LS	S	
	HR 4062L					S	S	S	LS	S	
	HR 4094R		.188	.094	.255	S	S	S	LS	S	
	HR 4094L					S	S	S	LS	S	
	HR 4125R		.250	.125	.255	S	S	LS	LS	LS	
	HR 4125L					S	S	S	LS	S	

S = Stock Standard LS = Limited Stock or Non-Stock - Call for Availability

Additional Full Nose Radius Sizes are Available on Request - Please Call for Availability

GROOVING INSERTS

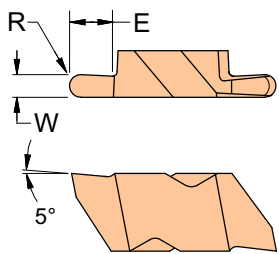
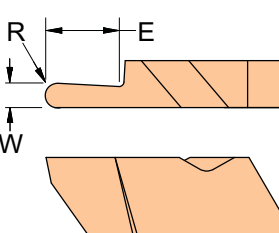
Style:	Insert Description		Dimensions			Grades				
HRP - 5° Positive Rake Full Nose Radius	Right Hand	Left Hand	W	R	E	C23	323FG	356FG	323	356
 <p>Right Hand Shown</p> <p>E Dimension is Maximum Depth of Cut</p> <p>Use RH Inserts with RH External Tool Holders</p> <p>Use LH Inserts with RH Internal Boring Bars</p> <p>For Tool Holder Information See Pages 31- 33</p>	HRP 2031R		.062	.031	.115	S	S	LS	LS	LS
		HRP 2031L				S	S	LS	LS	LS
	HRP 3031R		.062	.031	.130	S	S	S	LS	S
		HRP 3031L				S	S	LS	LS	LS
	HRP 3047R		.094	.047	.185	S	S	LS	LS	LS
		HRP 3047L				S	S	LS	LS	S
	HRP 3062R		.125	.062	.185	S	S	LS	LS	LS
		HRP 3062L				S	S	LS	LS	LS
	HRP 3078R		.156	.078	.185	S	S	LS	LS	LS
		HRP 3078L				S	LS	LS	LS	LS
	HRP 3094R		.188	.094	.185	S	S	S	LS	S
		HRP 3094L				S	S	S	LS	S
	HRP 4062R		.125	.062	.255	S	S	S	LS	S
		HRP 4062L				LS	LS	LS	LS	LS
	HRP 4094R		.188	.094	.255	LS	LS	LS	LS	LS
		HRP 4094L				S	LS	LS	LS	LS
HRP 4125R		.250	.125	.255	S	S	LS	LS	LS	
	HRP 4125L				S	LS	S	LS	S	
Additional Full Nose Radius Sizes Available on Request										
HRD - Full Nose Radius Deep Grooving	Right Hand	Left Hand	W	R	E	C23	323FG	356FG	323	356
 <p>Right Hand Shown</p> <p>E Dimension is Maximum Depth of Cut</p> <p>*HRD 3031R/L HRD 4062R/L Double Ended Deep Groovers Have Same Overall Length as Standard Size 3 and 4 Inserts</p>	HRD 3031R*		.062	.031	.192	S	S	LS	LS	LS
		HRD 3031L*				S	S	LS	LS	LS
	HRD 3047R		.094	.047	.255	S	S	LS	LS	LS
		HRD 3047L				S	S	LS	LS	LS
	HRD 3062R		.125	.062	.255	S	S	LS	LS	LS
		HRD 3062L				S	LS	LS	LS	LS
	HRD 3094R		.188	.094	.255	S	LS	LS	LS	LS
		HRD 3094L				S	LS	LS	LS	LS
	HRD 4062R*		.125	.062	.300	S	S	LS	LS	LS
		HRD 4062L*				LS	LS	LS	LS	LS
	HRD 4094R		.188	.094	.505	LS	LS	LS	LS	LS
		HRD 4094L				S	S	LS	LS	LS
HRD 4125R		.250	.125	.505	LS	LS	LS	LS	LS	
	HRD 4125L				S	S	LS	LS	LS	
Additional Full Nose Radius Sizes Available on Request										
S = Stock Standard LS = Limited Stock or Non-Stock - Call for Availability										

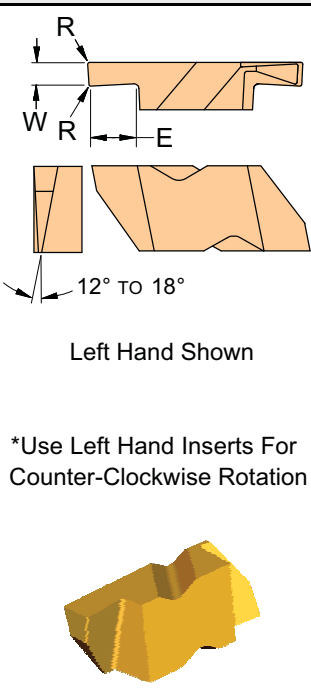
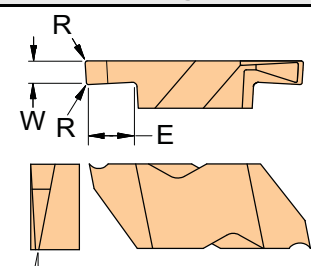
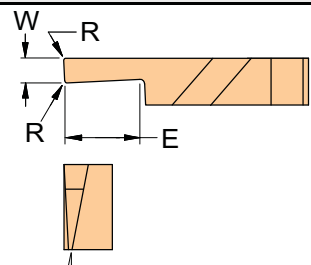
Style:	Insert Description		Dimensions			Grades				
HF - Face Grooving	Right Hand	Left Hand	W	R	E	C23	323FG	356FG	310	323
 <p>Left Hand Shown</p> <p>*Use Left Hand Inserts For Counter-Clockwise Rotation</p> <p>See Page 38 For Additional Face Grooving Information</p>	HF 3062R		.062	.0075	.125	LS	LS	LS	S	LS
		HF 3062L*		± .0025		LS	LS	LS	S	LS
	HF 3072R		.072	.0075	.125	LS	LS	LS	LS	LS
		HF 3072L*		± .0025		S	LS	LS	S	LS
	HF 3094R		.094	.0075	.185	LS	LS	LS	LS	LS
		HF 3094L*		± .0025		S	LS	LS	S	LS
	HF 3098R		.098	.0075	.185	LS	LS	LS	LS	LS
		HF 3098L*		± .0025		LS	LS	LS	LS	LS
	HF 3110R		.110	.0075	.185	LS	LS	LS	LS	LS
		HF 3110L*		± .0025		S	LS	LS	S	LS
	HF 3125R		.125	.0075	.185	S	LS	LS	LS	LS
		HF 3125L*		± .0025		LS	LS	LS	S	LS
	HF 3156R		.156	.0075	.185	LS	LS	LS	S	LS
		HF 3156L*		± .0025		LS	LS	LS	S	LS
	HF 3188R		.188	.0225	.185	LS	LS	LS	LS	LS
		HF 3188L*		± .0025		S	LS	LS	S	LS
HF 3189R		.189	.0225	.185	LS	LS	LS	LS	LS	
	HF 3189L*		± .0025		LS	LS	LS	LS	LS	
HF 4250R		.250	.0225	.255	LS	LS	LS	LS	LS	
	HF 4250L*		± .0025		LS	LS	LS	LS	LS	
HF - RK- LK Chip Curler Face Grooving	Right Hand	Left Hand	W	R	E	C23	323FG	356FG	310	323
 <p>Left Hand Shown</p> <p>*Use Left Hand Inserts For Counter-Clockwise Rotation See Page 44 For Additional Face Grooving Information</p>	HF 3094RK		.094	.0075	.185	LS	LS	LS	LS	LS
		HF 3094LK*		± .0025		LS	LS	LS	LS	LS
	HF 3125RK		.125	.0075	.185	LS	LS	LS	LS	LS
		HF 3125LK*		± .0025		LS	LS	LS	LS	LS
	HF 3156RK		.156	.0075	.185	LS	LS	LS	LS	LS
		HF 3156LK*		± .0025		LS	LS	LS	LS	LS
Style:	Insert Description		Dimensions			Grades				
HFD - Deep Face Grooving	Right Hand	Left Hand	W	R	E	C23	323FG	356FG	310	323
 <p>Left Hand Shown</p> <p>*Use Left Hand Inserts For Counter-Clockwise Rotation See Page 38 For Additional Face Grooving Information</p>	HF 3125R		.125	.0075	.255	S	LS	S	LS	LS
		HF 3125L*		± .0025		S	LS	S	LS	LS
	HF 4189R		.189	.0225	.505	S	LS	LS	LS	LS
		HF 4189L*		± .0025		S	LS	LS	LS	LS
	HF 4250R		.250	.0225	.505	LS	LS	LS	LS	LS
		HF 4250L*		± .0025		LS	LS	LS	LS	LS
<p>S = Stock Standard LS = Limited Stock or Non-Stock - Call for Availability</p>										

Style:		Insert Description		Dimensions			Grades					
Poly-V Grooving		Right Hand	Left Hand	H	R	E	C23	323FG	356FG	323	356	
<p>Right Hand Shown</p>	HV 3RJ		.087	.0125	.125	LS	LS	LS	LS	LS		
	HV 3LJ					S	LS	LS	LS	LS		
	HV 4RL		.118	.0125	.201	LS	LS	LS	LS	LS		
	HV 4LL					LS	LS	LS	LS	LS		
Undercutting		Right Hand	Left Hand	W	R	E	C23	323FG	356FG	323	356	
<p>Left Hand Shown</p>	HU 3094R		.094	.020	.125	LS	LS	LS	LS	LS		
	HU 3094L					LS	LS	LS	LS	LS		
	HU 3125R		.125	.047	.188	LS	LS	LS	LS	LS		
	HU 3125L					S	LS	LS	LS	LS		
	HU 3156R		.156	.047	.188	LS	LS	LS	LS	LS		
	HU 3156L					LS	LS	LS	LS	LS		
Precision Ground Blanks		Right Hand	Left Hand	A	T		C10	C23	C56			
<p>Right Hand Shown</p>	HB 2R		.219	.150		LS	S	S				
	HB 2L					LS	S	S				
	HB 3R		.344	.195		LS	S	S				
	HB 3L					LS	S	S				
	HB 4R		.453	.255		LS	S	S				
	HB 4L					LS	S	S				
	HB 5R		.688	.380		LS	LS	LS				
	HB 5L					LS	LS	LS				
	HB 6R		.453	.380		LS	LS	LS				
	HB L					LS	LS	LS				
	Precision Ground Deep Grooving Blanks		Right Hand	Left Hand	A	T		C10	C23	C56		
	<p>Right Hand Shown</p>	HBD 2R		.219	.150		LS	S	S			
HBD 2L					LS	S	S					
HBD 3R		.344	.195		LS	S	S					
HBD 3L					LS	S	S					
HBD 4R		.453	.255		LS	S	S					
HBD 4L					LS	S	S					

S = Stock Standard LS = Limited Stock or Non-Stock - Call for Availability

Style:	Insert	Dimensions			Grades				
	Description	W	H	S	C23	323FG	356FG	323	356
	VDB 125 A015	.125	.250	.106	S	S	LS	LS	S
	VDB 156 A015	.156	.250	.106	S	S	LS	LS	LS
	VDB 188 A015	.188	.250	.144	S	S	LS	LS	S
	VDB 218 A015	.218	.250	.144	S	S	LS	LS	LS
	VDB 250 A015	.250	.250	.144	S	S	LS	LS	S
	VDB 250 B015	.250	.337	.144	S	S	LS	LS	LS
	VDB 281 B015	.281	.337	.202	S	S	LS	LS	LS
	VDB 312 B015	.312	.337	.202	LS	LS	LS	LS	LS
	VDB 344 B015	.344	.337	.276	LS	LS	LS	LS	LS
	VDB 375 B015	.375	.337	.276	LS	LS	LS	LS	LS
	Description	W	H	S	C23	323FG	356FG	323	356
	VDB 125 A015C	.125	.250	.106	S	S	S	LS	S
	VDB 156 A015C	.156	.250	.106	LS	LS	LS	LS	LS
	VDB 188 A015C	.188	.250	.144	S	S	LS	LS	LS
	VDB 250 A015C	.250	.250	.144	S	S	LS	LS	LS
	VDB 250 B015C	.250	.337	.144	LS	LS	LS	LS	LS
	Description	R	W	H	C23	323FG	356FG	323	356
	VDB 125 RA	.062	.125	.250	S	LS	LS	LS	LS
	VDB 156 RA	.078	.156	.250	LS	LS	LS	LS	LS
	VDB 188 RA	.094	.188	.250	S	LS	LS	LS	LS
	VDB 218 RA	.109	.218	.250	LS	LS	LS	LS	LS
	VDB 250 RA	.125	.250	.250	S	LS	LS	LS	LS
	VDB 250 RB	.125	.250	.337	LS	LS	LS	LS	LS
	VDB 281 RB	.140	.281	.337	LS	LS	LS	LS	LS
	VDB 312 RB	.156	.312	.337	LS	LS	LS	LS	LS
	VDB 344 RB	.172	.344	.337	LS	LS	LS	LS	LS
VDB 375 RB	.187	.375	.337	LS	LS	LS	LS	LS	
	Description	W	H	L	C23	323FG	356FG	323	356
	GC 4125	.125	.188	1.000	S	S	S	LS	S
	GC 4187	.187	.328	1.000	S	LS	LS	LS	LS
	GC 4250	.250	.328	1.000	LS	LS	LS	LS	LS
	GC 4312	.312	.328	1.000	LS	LS	LS	LS	LS
	GC 4375	.375	.328	1.000	LS	LS	LS	LS	LS
	GC 6187	.187	.328	1.500	LS	LS	LS	LS	LS
	GC 6250	.250	.328	1.500	LS	LS	LS	LS	LS
	GC 6312	.312	.328	1.500	LS	LS	LS	LS	LS

S = Stock Standard LS = Limited Stock or Non-Stock - Call for Availability

GROOVING INSERTS

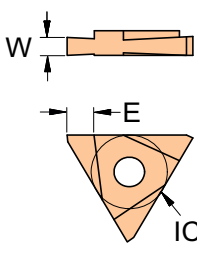
Style:	Insert	Dimensions			Grades				
TNMA On Edge Grooving	Description	W	E	IC	C23	323FG	356FG	323	356
 <p>Right Hand Shown</p> <p>NGR = Right Hand NGL = Left Hand NGC = Center</p> <p>Sharp Corners - No Radius</p> <p>TNMA Inserts for use in Carboloy® Tool Holders Only</p>	TNMA 32NGR 062	.062	.156	.375	S	LS	LS	LS	LS
	TNMA 32NGL 062	.062	.156	.375	S	LS	LS	LS	LS
	TNMA 32NGC 062	.062	.156	.375	LS	LS	LS	LS	LS
	TNMA 32NGR 094	.094	.156	.375	S	LS	LS	LS	LS
	TNMA 32NGL 094	.094	.156	.375	LS	LS	LS	LS	LS
	TNMA 32NGC 094	.094	.156	.375	LS	LS	LS	LS	LS
	TNMA 32NG 125	.125	.156	.375	LS	LS	LS	LS	LS
	TNMA 43NGR 062	.062	.156	.500	LS	LS	LS	LS	LS
	TNMA 43NGL 062	.062	.156	.500	LS	LS	LS	LS	LS
	TNMA 43NGC 062	.062	.156	.500	LS	LS	LS	LS	LS
	TNMA 43NGR 094	.094	.234	.500	S	S	LS	LS	LS
	TNMA 43NGL 094	.094	.234	.500	LS	LS	LS	LS	LS
	TNMA 43NGC 094	.094	.234	.500	LS	LS	LS	LS	LS
	TNMA 43NGR 125	.125	.234	.500	LS	LS	LS	LS	LS
	TNMA 43NGL 125	.125	.234	.500	LS	LS	LS	LS	LS
	TNMA 43NGC 125	.125	.234	.500	LS	LS	LS	LS	LS
TNMA 43NG 187	.187	.234	.500	LS	LS	LS	LS	LS	

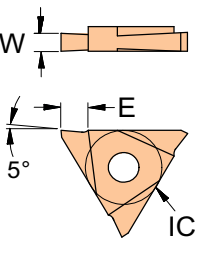
Style:	Insert	Dimensions			Grades				
TPMA On Edge Grooving	Description	W	E	IC	C23	323FG	356FG	323	356
 <p>Right Hand Shown</p> <p>NGR = Right Hand NGL = Left Hand NGC = Center</p> <p>Sharp Corners - No Radius</p> <p>TPMA Inserts for use in Carboloy® Tool Holders Only</p>	TPMA 32NGR 062	.062	.156	.375	S	S	LS	LS	LS
	TPMA 32NGL 062	.062	.156	.375	LS	LS	LS	LS	LS
	TPMA 32NGC 062	.062	.156	.375	LS	LS	LS	LS	LS
	TPMA 32NGR 094	.094	.156	.375	LS	LS	LS	LS	LS
	TPMA 32NGL 094	.094	.156	.375	LS	LS	LS	LS	LS
	TPMA 32NGC 094	.094	.156	.375	LS	LS	LS	LS	LS
	TPMA 32NG 125	.125	.156	.375	LS	LS	LS	LS	LS
	TPMA 43NGR 062	.062	.156	.500	S	S	LS	LS	LS
	TPMA 43NGL 062	.062	.156	.500	LS	LS	LS	LS	LS
	TPMA 43NGC 062	.062	.156	.500	LS	LS	LS	LS	LS
	TPMA 43NGR 094	.094	.234	.500	LS	LS	LS	LS	LS
	TPMA 43NGL 094	.094	.234	.500	LS	LS	LS	LS	LS
	TPMA 43NGC 094	.094	.234	.500	LS	LS	LS	LS	LS
	TPMA 43NGR 125	.125	.234	.500	S	S	LS	LS	LS
	TPMA 43NGL 125	.125	.234	.500	LS	LS	LS	LS	LS
	TPMA 43NGC 125	.125	.234	.500	LS	LS	LS	LS	LS
TPMA 43NG 187	.187	.234	.500	LS	LS	LS	LS	LS	

S = Stock Standard LS = Limited Stock or Non-Stock - Call for Availability

Additional Sizes Available on Request

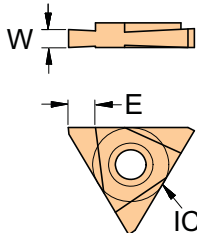
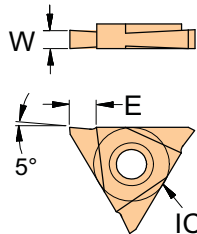
Style:	Insert	Dimensions			Grades				
TNMC On Edge Grooving	Description	W	E	IC	C23	323FG	356FG	323	356
 <p>Right Hand Shown</p> <p>NGR = Right Hand NGL = Left Hand NGC = Center</p> <p>Sharp Corners - No Radius</p> <p>Additional Sizes Available on Request</p> <p>TNMC Inserts fit all Industry Std. Tool Holders except Carboloy®</p>	TNMC 32NGR 032	.032	.057	.375	S	S	LS	LS	LS
	TNMC 32NGL 032	.032	.057	.375	S	LS	LS	LS	LS
	TNMC 32NGC 032	.032	.057	.375	LS	LS	LS	LS	LS
	TNMC 32NGR 062	.062	.156	.375	S	S	LS	LS	LS
	TNMC 32NGL 062	.062	.156	.375	LS	LS	LS	LS	LS
	TNMC 32NGC 062	.062	.156	.375	LS	LS	LS	LS	LS
	TNMC 32NGR 094	.094	.156	.375	S	S	LS	LS	LS
	TNMC 32NGL 094	.094	.156	.375	S	S	LS	LS	LS
	TNMC 32NGC 094	.094	.156	.375	LS	LS	LS	LS	LS
	TNMC 32NG 125	.125	.156	.375	S	S	LS	LS	LS
	TNMC 43NGR 062	.062	.156	.500	S	S	LS	LS	LS
	TNMC 43NGL 062	.062	.156	.500	S	S	LS	LS	LS
	TNMC 43NGC 062	.062	.156	.500	LS	LS	LS	LS	LS
	TNMC 43NGR 094	.094	.234	.500	S	S	LS	LS	LS
	TNMC 43NGL 094	.094	.234	.500	S	LS	LS	LS	LS
	TNMC 43NGC 094	.094	.234	.500	LS	LS	LS	LS	LS
	TNMC 43NGR 125	.125	.234	.500	S	S	LS	LS	LS
	TNMC 43NGL 125	.125	.234	.500	S	S	LS	LS	LS
	TNMC 43NGC 125	.125	.234	.500	LS	LS	LS	LS	LS
	TNMC 43NGR 156	.156	.234	.500	LS	LS	LS	LS	LS
	TNMC 43NGL 156	.156	.234	.500	LS	LS	LS	LS	LS
	TNMC 43NGC 156	.156	.234	.500	LS	LS	LS	LS	LS
	TNMC 43NG 187	.187	.234	.500	LS	LS	LS	LS	LS
	TNMC 54NGR 156	.156	.275	.625	LS	LS	LS	LS	LS
	TNMC 54NGL 156	.156	.275	.625	LS	LS	LS	LS	LS
	TNMC 54NGR 187	.187	.275	.625	LS	LS	LS	LS	LS
TNMC 54NGL 187	.187	.275	.625	LS	LS	LS	LS	LS	
Style:	Insert	Dimensions			Grades				
TPMC On Edge Grooving	Description	W	E	IC	C23	323FG	356FG	323	356
 <p>Right Hand Shown</p> <p>NGR = Right Hand NGL = Left Hand NGC = Center</p> <p>TPMC Inserts fit all Industry Std. Tool Holders except Carboloy®</p>	TPMC 32NGR 062	.062	.156	.375	S	S	LS	LS	LS
	TPMC 32NGL 062	.062	.156	.375	S	S	LS	LS	LS
	TPMC 32NGC 062	.062	.156	.375	LS	LS	LS	LS	LS
	TPMC 32NGR 094	.094	.156	.375	S	LS	LS	LS	LS
	TPMC 32NGL 094	.094	.156	.375	S	S	LS	LS	LS
	TPMC 32NGC 094	.094	.156	.375	LS	LS	LS	LS	LS
	TPMC 32NG 125	.125	.156	.375	LS	LS	LS	LS	LS
	TPMC 43NGR 062	.062	.156	.500	S	LS	LS	LS	LS
	TPMC 43NGL 062	.062	.156	.500	S	LS	LS	LS	LS
	TPMC 43NGC 062	.062	.156	.500	LS	LS	LS	LS	LS
	TPMC 43NGR 094	.094	.234	.500	S	LS	LS	LS	LS
	TPMC 43NGL 094	.094	.234	.500	S	LS	LS	LS	LS
	TPMC 43NGC 094	.094	.234	.500	LS	LS	LS	LS	LS
	TPMC 43NGR 125	.125	.234	.500	S	LS	LS	LS	LS
	TPMC 43NGL 125	.125	.234	.500	S	LS	LS	LS	LS
	TPMC 43NGC 125	.125	.234	.500	LS	LS	LS	LS	LS
TPMC 43NG 187	.187	.234	.500	LS	LS	LS	LS	LS	

S = Stock Standard LS = Limited Stock or Non-Stock - Call for Availability

THREADING INSERTS

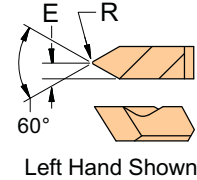
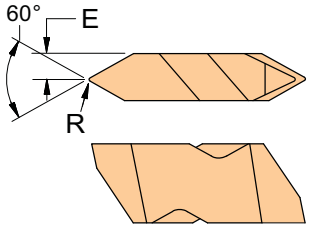
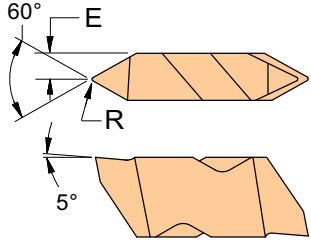
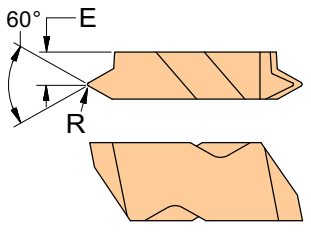
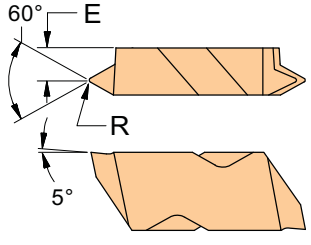
Style:	Insert Description		Dimensions			Grades					
HT Size 1 ID Threading  Left Hand Shown	Right Hand	Left Hand	PITCH	R	E	C10	310FG	310			
	N/A	HT 1L	12 - 24 tpi ID	0.003	.045	N/A	N/A	N/A			
				± .001		S	S	S			
Style:	Insert Description		Dimensions			Grades					
HT General Purpose  Right Hand Shown	Right Hand	Left Hand	PITCH	R	E	C23	323FG	356FG	310	323	356
	HT 2R		8 - 36 tpi OD	.004	.075	S	S	S	S	LS	S
		HT 2L	7 - 20 tpi ID	± .001		S	S	S	S	LS	S
	HT 3R		6 - 20 tpi OD	.0065	.098	S	S	S	S	LS	S
		HT 3L	5 - 12 tpi ID	± .0015		S	S	S	S	LS	S
	HT 4R		4 - 20 tpi OD	.0065	.128	S	S	S	S	LS	S
	HT 4L	4 - 12 tpi ID	± .0015		S	S	S	S	LS	S	
Use RH Inserts with RH External Holders - LH Inserts with RH Boring Bars See Pages 31-33											
Style:	Insert Description		Dimensions			Grades					
HTP 5° Positive Rake  Right Hand Shown	Right Hand	Left Hand	PITCH	R	E	C23	323FG	356FG	310	323	356
	HTP 2R		8 - 36 tpi OD	.004	.075	S	S	S	S	LS	S
		HTP 2L	7 - 20 tpi ID	± .001		S	S	S	S	LS	S
	HTP 3R		6 - 20 tpi OD	.0065	.098	S	S	S	S	LS	S
		HTP 3L	5 - 12 tpi ID	± .0015		S	S	S	S	LS	S
	HTP 4R		4 - 20 tpi OD	.0065	.128	S	S	S	S	LS	S
	HTP 4L	4 - 12 tpi ID	± .0015		S	S	S	S	LS	S	
Use RH Inserts with RH External Holders - LH Inserts with RH Boring Bars See Pages 31-33											
Style:	Insert Description		Dimensions			Grades					
HTF Close Shoulder  Right Hand Shown	Right Hand	Left Hand	PITCH	R	E	C23	323FG	356FG	310	323	356
	HTF 2R		14-44 tpi OD	.003	.110	S	S	S	S	LS	S
		HTF 2L	12-24 tpi ID	± .001		S	S	S	S	LS	S
	HTF 3R		10-44 tpi OD	.003	.141	S	S	S	S	LS	S
		HTF 3L	9-24 tpi ID	± .0015		S	S	S	S	LS	S
	HTF 4R		10-44 tpi OD	.003	.201	S	S	S	S	LS	S
	HTF 4L	9-24 tpi ID	± .0015		S	S	S	S	LS	S	
Use RH Inserts with RH External Holders - LH Inserts with RH Boring Bars See Pages 31-33											
Style:	Insert Description		Dimensions			Grades					
HTK 5° Positive Rake  Right Hand Shown	Right Hand	Left Hand	PITCH	R	E	C23	323FG	356FG	310	323	356
	HTK 2R		14-44 tpi OD	.003	.110	S	S	S	S	LS	S
		HTK 2L	12-24 tpi ID	± .001		S	S	S	S	LS	S
	HTK 3R		10-44 tpi OD	.003	.141	S	S	S	S	LS	S
		HTK 3L	9-24 tpi ID	± .0015		S	S	S	S	LS	S
	HTK 4R		10-44 tpi OD	.003	.201	S	S	S	S	LS	S
	HTK 4L	9-24 tpi ID	± .0015		S	S	S	S	LS	S	
Use RH Inserts with RH External Holders - LH Inserts with RH Boring Bars See Pages 31-33											

S = Stock Standard LS = Limited Stock or Non-Stock - Call for Availability

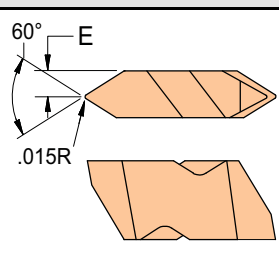
Style:	Insert Description		Dimensions			Grades					
HT - C and HTP - C Coarse Pitch .015R  Right Hand Shown	Right Hand	Left Hand	PITCH	R	E	C23	323FG	356FG	310	323	356
	HT 3RC		6-11 tpi	.015	.098	LS	LS	LS	S	LS	LS
		HT 3LC		6 tpi	-.001	.098	LS	LS	LS	LS	LS
	HTP 3RC		6-11 tpi	.015	.098	LS	LS	LS	S	LS	LS
		HTP 3LC		6 tpi	-.001	.098	LS	LS	LS	LS	LS
	HT 4RC		4.5-11 tpi	.015	.128	LS	LS	LS	LS	LS	LS
	HT 4LC		4.5-6 tpi	-.001	.128	LS	LS	LS	LS	LS	

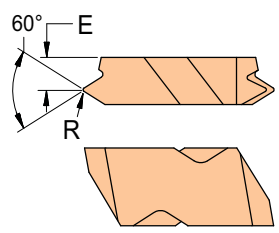
Style:	Insert Description		Dimensions			Grades					
Cresting Style Full Profile 60°  External RH Shown For Removing Burr From Crest of Thread * Use LH Inserts For RH Internal Threads For Tool Holder Information See Pages 31-33	External RH	Internal LH*	PITCH	R	E	C23	323FG	356FG	310	323	356
	HTC 3R8E		8	.0150	.107	LS	LS	LS	S	LS	S
		HTC 3L8I		TPI	.0070	.107	LS	LS	LS	S	LS
	HTC 3R10E		10	.0124	.107	LS	LS	LS	LS	LS	LS
		HTC 3L10I		TPI	.0052	.107	LS	LS	LS	LS	LS
	HTC 3R12E		12	.0100	.148	S	S	LS	S	LS	S
		HTC 3L12I		TPI	.0040	.148	S	S	LS	S	S
	HTC 3R14E		14	.0088	.148	LS	LS	LS	S	LS	S
		HTC 3L14I		TPI	.0037	.148	LS	LS	LS	LS	LS
	HTC 3R16E		16	.0075	.148	S	S	LS	S	LS	LS
		HTC 3L16I		TPI	.0030	.148	LS	LS	LS	S	LS
	HTC 3R18E		18	.0070	.148	LS	LS	LS	LS	LS	LS
		HTC 3L18I		TPI	.0030	.148	LS	LS	LS	LS	LS
	HTC 3R20E		20	.0062	.148	S	S	LS	S	LS	LS
		HTC 3L20I		TPI	.0026	.148	LS	LS	LS	LS	LS
	HTC 3R24E		24	.0045	.148	LS	LS	LS	S	LS	LS
		HTC 3L24I		TPI	.0015	.148	LS	LS	LS	LS	LS
	HTC 3R28E		12	.0039	.148	LS	LS	LS	LS	LS	LS
	HTC 3L28I		TPI	.0013	.148	LS	LS	LS	LS	LS	
HTC 3R32E		10	.0034	.148	LS	LS	LS	S	LS	LS	
	HTC 3L32I		TPI	.0010	.148	LS	LS	LS	LS	LS	

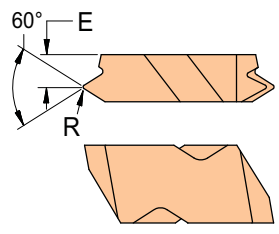
Style:	Insert Description		Dimensions			Grades					
Cresting Style NPT  External RH Shown * Use LH Inserts For RH Internal Threads	External RH	Internal LH*	PITCH	R	E	C23	323FG	356FG	310	323	356
	HDC 38VR-75		8	.0050	.100	LS	LS	LS	LS	LS	S
		HDC 38VL-75		NPT	.0050	.100	LS	LS	LS	LS	LS
	HDC 3115VR-75		11.5	.0040	.144	LS	LS	LS	S	LS	S
		HDC 3115VL-75		NPT	.0040	.144	LS	LS	LS	S	LS
	HDC 314VR-75		14	.0030	.144	LS	LS	LS	S	LS	LS
		HDC 314VL-75		NPT	.0030	.144	LS	LS	LS	LS	LS
	HDC 318VR-75		18	.0030	.144	LS	LS	LS	LS	LS	LS
	HDC 318VL-75		NPT	.0030	.144	LS	LS	LS	LS	LS	
HDC 327VR-75		27	.0020	.144	LS	LS	LS	S	LS	LS	
	HDC 327VL-75		NPT	.0020	.144	LS	LS	LS	LS	LS	

S = Stock Standard LS = Limited Stock or Non-Stock - Call for Availability

THREADING INSERTS - ACME

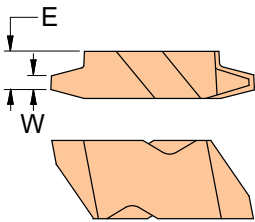
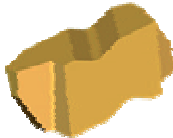
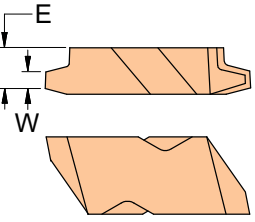
Style:	Insert Description		Dimensions			Grades					
HA - Acme	Right Hand	Left Hand*	PITCH	W	E	C23	323FG	356FG	310	323	356
 <p>Right Hand Shown</p> <p>* Use LH Inserts For RH Internal Threads</p> <p>For Tool Holder Information See Pages 31-33</p>  <p>Left Hand Insert</p>	HA 3R16		16	.0206	.149	LS	LS	LS	LS	LS	LS
		HA 3L16	ACME			LS	LS	LS	LS	LS	LS
	HA 3R14		14	.0239	.149	LS	LS	LS	LS	LS	LS
		HA 3L14	ACME			LS	LS	LS	LS	LS	LS
	HA 3R12		12	.0283	.149	LS	LS	LS	LS	LS	LS
		HA 3L12	ACME			LS	LS	LS	LS	LS	LS
	HA 3R10		10	.0319	.149	LS	LS	LS	S	LS	LS
		HA 3L10	ACME			LS	LS	LS	LS	LS	LS
	HA 3R8		8	.0411	.149	S	S	LS	S	LS	LS
		HA 3L8	ACME			S	S	LS	S	LS	LS
	HA 3R6		6	.0566	.149	S	LS	LS	LS	LS	LS
		HA 3L6	ACME			LS	LS	LS	LS	LS	LS
	HA 3R5		5	.0689	.133	S	S	LS	S	LS	LS
		HA 3L5	ACME			S	S	LS	S	LS	LS
	HA 3R4		4	.0875	.133	LS	LS	LS	LS	LS	LS
		HA 3L4	ACME			LS	LS	LS	LS	LS	LS
	HA 4R10		10	.0319	.202	LS	LS	LS	LS	LS	LS
		HA 4L10	ACME			LS	LS	LS	LS	LS	LS
	HA 4R8		8	.0411	.202	LS	LS	LS	LS	LS	LS
		HA 4L8	ACME			LS	LS	LS	LS	LS	LS
	HA 4R6		6	.0566	.202	LS	LS	LS	LS	LS	LS
		HA 4L6	ACME			LS	LS	LS	LS	LS	LS
	HA 4R5		5	.0689	.202	LS	LS	LS	LS	LS	LS
		HA 4L5	ACME			LS	LS	LS	LS	LS	LS
	HA 4R4		4	.0875	.202	LS	LS	LS	LS	LS	LS
		HA 4L4	ACME			LS	LS	LS	LS	LS	LS
	HA 6R3		3	.1184	.283	LS	LS	LS	LS	LS	LS
		HA 6L3	ACME			LS	LS	LS	LS	LS	LS
HA 6R25		2.5	.1431	.283	LS	LS	LS	LS	LS	LS	
	HA 6L25	ACME			LS	LS	LS	LS	LS	LS	
HA 6R2		2	.1802	.283	LS	LS	LS	LS	LS	LS	
	HA 6L2	ACME			LS	LS	LS	LS	LS	LS	
Style:	Insert Description		Dimensions			Grades					
HAS - Stub Acme	Right Hand	Left Hand*	PITCH	W	E	C23	323FG	356FG	310	323	356
 <p>Right Hand Shown</p> <p>* Use LH Inserts For RH Internal Threads</p>	HAS 3R16		16	.0238	.149	LS	LS	LS	LS	LS	LS
		HAS 3L16	S ACME			LS	LS	LS	LS	LS	LS
	HAS 3R14		14	.0276	.149	LS	LS	LS	LS	LS	LS
		HAS 3L14	S ACME			LS	LS	LS	LS	LS	LS
	HAS 3R12		12	.0326	.149	LS	LS	LS	LS	LS	LS
		HAS 3L12	S ACME			LS	LS	LS	LS	LS	LS
	HAS 3R10		10	.0370	.149	S	LS	LS	LS	LS	LS
		HAS 3L10	S ACME			LS	LS	LS	LS	LS	LS
	HAS 3R8		8	.0476	.149	LS	LS	LS	LS	LS	LS
		HAS 3L8	S ACME			LS	LS	LS	LS	LS	LS
	HAS 3R6		6	.0652	.149	LS	LS	LS	LS	LS	LS
		HAS 3L6	S ACME			LS	LS	LS	LS	LS	LS
	HAS 3R5		5	.0793	.149	LS	LS	LS	S	LS	LS
		HAS 3L5	S ACME			LS	LS	LS	S	LS	LS
S = Stock Standard LS = Limited Stock or Non-Stock - Call for Availability											

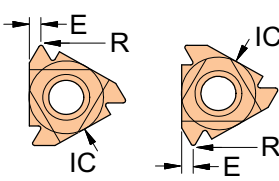
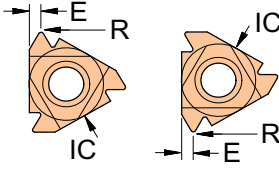
Style:	Insert Description		Dimensions				Grades		
Partial Profile 60°	External RH	Internal RH	PITCH	R	E	IC	323FG	356FG	323F
 <p>External RH Internal RH</p> <p>Call for Availability On Left Hand Inserts</p>	NA	11NR A60	16 - 48	.003	.039	.250	S	LS	LS
	16ER A60		16 - 48	.003	.039	.375	S	LS	LS
		16NR A60	TPI	.003			S	LS	LS
	16ER AG60		8 - 48	.003	.059	.375	S	LS	S
		16NR AG60	TPI	.003			S	LS	S
	16ER G60		8 - 14	.007	.059	.375	LS	LS	LS
		16NR G60	TPI	.005			LS	LS	LS
	22ER N60		5 - 7	.016	.098	.500	LS	LS	LS
		22NR N60	TPI	.010			LS	LS	LS
	27ER Q60		4 - 4.5	.025	.126	.625	LS	LS	LS
	27NR Q60	TPI	.012			LS	LS	LS	
Full Profile 60°	External RH	Internal RH	PITCH	R *	E	IC	323FG	356FG	323F
 <p>External RH Internal RH</p> <p>Call for Availability On Left Hand Inserts</p> <p>* Insert Nose Radius: Internal = .125 x Pitch External = .1443 x Pitch</p>	16ER 40UN		40		.020	.375	LS	LS	LS
		16NR 40UN	TPI				LS	LS	LS
	16ER 36UN		36		.020	.375	LS	LS	LS
		16NR 36UN	TPI				LS	LS	LS
	16ER 32UN		32		.020	.375	S	LS	LS
		16NR 32 UN	TPI				S	LS	LS
	16ER 28UN		28		.020	.375	S	LS	LS
		16NR 28UN	TPI				S	LS	LS
	16ER 24UN		24		.031	.375	S	LS	LS
		16NR 24UN	TPI				S	LS	LS
	16ER 20UN		20		.031	.375	S	LS	S
		16NR 20UN	TPI				S	LS	S
	16ER 18UN		18		.031	.375	S	LS	LS
		16NR 18UN	TPI				S	LS	LS
	16ER 16UN		16		.031	.375	S	LS	S
		16NR 16UN	TPI				S	LS	S
	16ER 14UN		14		.059	.375	S	LS	LS
		16NR 14UN	TPI				S	LS	LS
	16ER 13UN		13		.059	.375	LS	LS	LS
		16NR 13UN	TPI				LS	LS	LS
	16ER 12UN		12		.059	.375	S	LS	S
		16NR 12UN	TPI				S	LS	S
	16ER 10UN		10		.059	.375	LS	LS	LS
		16NR 10UN	TPI				LS	LS	LS
	16ER 9UN		9		.059	.375	LS	LS	LS
		16NR 9UN	TPI				LS	LS	LS
	16ER 8UN		8		.059	.375	LS	LS	LS
		16NR 8UN	TPI				LS	LS	LS
	22ER 7UN		7		.098	.500	LS	LS	LS
		22NR 7UN	TPI				LS	LS	LS
22ER 6UN		6		.098	.500	LS	LS	LS	
	22NR 6UN	UN				LS	LS	LS	
22ER 5UN		5		.098	.500	LS	LS	LS	
	22NR 5UN	UN				LS	LS	LS	
S = Stock Standard LS = Limited Stock or Non-Stock - Call for Availability									

LAYDOWN THREADING INSERTS 22

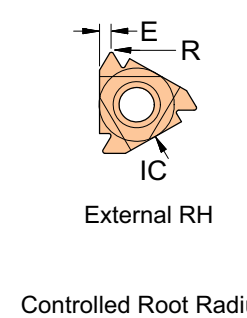
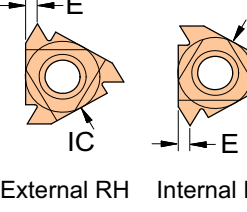
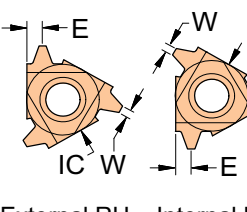
Style:	Insert Description		Dimensions				Grades		
Full Profile UNJ	External RH	Internal RH	PITCH	R	E	IC	323FG	356FG	323F
 <p>External RH</p> <p>Controlled Root Radius UNJ Threading Inserts</p>	16ER 32UNJ	NA	32 UNJ	.0047	.020	.375	LS	LS	LS
	16ER 28UNJ	NA	28 UNJ	.0054	.020	.375	LS	LS	LS
	16ER 24UNJ	NA	24 UNJ	.0063	.031	.375	LS	LS	LS
	16ER 20UNJ	NA	20UNJ	.0075	.031	.375	LS	LS	LS
	16ER 18UNJ	NA	18 UNJ	.0083	.031	.375	LS	LS	LS
	16ER 16UNJ	NA	16 UNJ	.0094	.031	.375	LS	LS	LS
	16ER 14UNJ	NA	14 UNJ	.0107	.059	.375	LS	LS	LS
	16ER 12UNJ	NA	12 UNJ	.0125	.059	.375	LS	LS	LS
	16ER 10UNJ	NA	10 UNJ	.0150	.059	.375	LS	LS	LS
	16ER 8UNJ	NA	8 UNJ	.0188	.059	.375	LS	LS	LS
Full Profile NPT	External RH	Internal RH	PITCH	R	E	IC	323FG	356FG	323F
 <p>External RH Internal RH</p>	16ER 27NPT		27	NA	.020	.375	S	LS	LS
		16NR 27NPT	NPT				LS	LS	LS
	16ER 18NPT		18		.031	.375	S	LS	LS
		16NR 18NPT	NPT				S	LS	LS
	16ER 14NPT		14		.059	.375	S	LS	LS
		16NR 14NPT	NPT				S	LS	LS
	16ER 11.5NPT		11.5		.059	.375	S	LS	LS
		16NR 11.5NPT	NPT				S	LS	LS
16ER 8NPT		8		.063	.375	LS	LS	LS	
	16NR 8NPT	NPT				LS	LS	LS	
Full Profile Acme	External RH	Internal RH	PITCH	W	E	IC	323FG	356FG	323F
 <p>External RH Internal RH</p>	16ER 16 ACME		16	.0206	.031	.375	LS	LS	LS
		16NR 16 ACME	ACME				LS	LS	LS
	16ER 14 ACME		14	.0239	.059	.375	LS	LS	LS
		16NR 14 ACME	ACME				LS	LS	LS
	16ER 12 ACME		12	.0283	.059	.375	LS	LS	LS
		16NR 12 ACME	ACME				LS	LS	LS
	16ER 10 ACME		10	.0319	.059	.375	LS	LS	LS
		16NR 10 ACME	ACME				LS	LS	LS
	16ER 8 ACME		8	.0411	.059	.375	LS	LS	LS
		16NR 8 ACME	ACME				LS	LS	LS
	22ER 6 ACME		6	.0566	.098	.500	LS	LS	LS
		22NR 6 ACME	ACME				LS	LS	LS
	22ER 5 ACME		5	.0689	.091	.500	LS	LS	LS
	22NR 5 ACME	ACME				LS	LS	LS	
27ER 4 ACME		4	.0875	.118	.625	LS	LS	LS	

S = Stock Standard LS = Limited Stock or Non-Stock - Call for Availability

23 LAYDOWN THREADING INSERTS

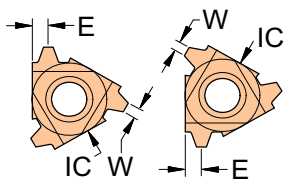
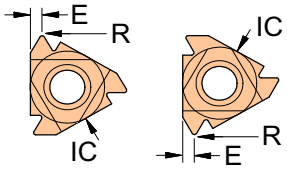
Style:	Insert Description		Dimensions				Grades		
Full Profile Stub Acme  External RH Internal RH	External RH	Internal RH	PITCH	W	E	IC	323FG	356FG	323F
	16ER 16STACME		16	.0238	.039	.375	LS	LS	LS
		16NR 16STACME	ST ACME				LS	LS	LS
	16ER 14STACME		14	.0276	.051	.375	LS	LS	LS
		16NR 14STACME	ST ACME				LS	LS	LS
	16ER 12STACME		12	.0326	.059	.375	LS	LS	LS
		16NR 12STACME	ST ACME				LS	LS	LS
	16ER 10STACME		10	.0370	.059	.375	LS	LS	LS
		16NR 10STACME	ST ACME				LS	LS	LS
	16ER 8STACME		8	.0476	.063	.375	LS	LS	LS
		16NR 8STACME	ST ACME				LS	LS	LS
	22ER 6TSACME		6	.0652	.091	.500	LS	LS	LS
		22NR 6STACME	ST ACME				LS	LS	LS
	22ER 5STACME		5	.0793	.079	.500	LS	LS	LS
		22NR 5STACME	ST ACME				LS	LS	LS
	27ER 4STACME		4	.1004	.102	.625	LS	LS	LS
	27NR 4STACME	ST ACME				LS	LS	LS	
Style:	Insert Description		Dimensions				Grades		
Full Profile ISO Metric  External RH Internal RH Call for Availability On Left Hand Inserts * Insert Nose Radius: Internal = .125 x Pitch External = .1443 x Pitch	External RH	Internal RH	PITCH	R *	E	IC	323FG	356FG	323F
	16ER 0.50 ISO		0.50		.020	.375	LS	LS	LS
		16NR 0.50 ISO	mm				LS	LS	LS
	16ER 0.75 ISO		0.75		.020	.375	LS	LS	LS
		16NR 0.75 ISO	mm				LS	LS	LS
	16ER 1.00 ISO		1.00		.031	.375	LS	LS	LS
		16NR 1.00 ISO	mm				LS	LS	LS
	16ER 1.25 ISO		1.25		.031	.375	LS	LS	LS
		16NR 1.25 ISO	mm				LS	LS	LS
	16ER 1.50 ISO		1.50		.059	.375	LS	LS	LS
		16NR 1.50 ISO	mm				LS	LS	LS
	16ER 1.75 ISO		1.75		.059	.375	LS	LS	LS
		16NR 1.75 ISO	mm				LS	LS	LS
	16ER 2.00 ISO		2.00		.059	.375	LS	LS	LS
		16NR 2.00 ISO	mm				LS	LS	LS
	16ER 2.50 ISO		2.50		.059	.375	LS	LS	LS
	16NR 2.50 ISO	mm				LS	LS	LS	
16ER 3.00 ISO		3.00		.059	.375	LS	LS	LS	
	16NR 3.00 ISO	mm				LS	LS	LS	
S = Stock Standard LS = Limited Stock or Non-Stock - Call for Availability									

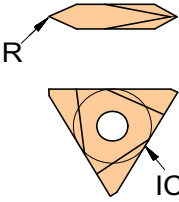
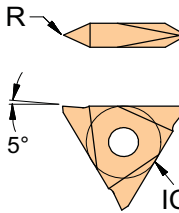
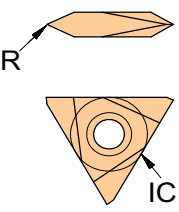
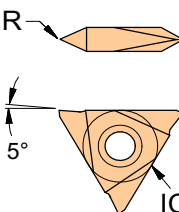
Style:	Insert	Dimensions					Grades			
TNMA On Edge Threading	Description	PITCH	R	IC	C23	323FG	356FG	323	356	
 <p>TNMA Inserts for use in Carbology® Tool Holders Only</p>	TNMA 32NV	8 tpi Max	.003 -.005	.375	LS	LS	LS	LS	LS	
	TNMA 43NV	6 tpi Max	.005 -.008	.500	LS	LS	LS	LS	LS	
	TNMA 54NV	4 tpi Max	.005 -.008	.625	LS	LS	LS	LS	LS	
Style:	Insert	Dimensions					Grades			
TPMA Positive Rake On Edge Threading	Description	PITCH	R	IC	C23	323FG	356FG	323	356	
 <p>TPMA Inserts for use in Carbology® Tool Holders Only</p>	TPMA 32NV	8 tpi Max	.003 -.005	.375	LS	LS	S	LS	S	
	TPMA 43NV	6 tpi Max	.005 -.008	.500	LS	LS	LS	LS	LS	
	TPMA 54NV	4 tpi Max	.005 -.008	.625	LS	LS	LS	LS	LS	
Style:	Insert	Dimensions					Grades			
TNMC On Edge Threading	Description	PITCH	R	IC	C23	323FG	356FG	323	356	
 <p>TNMC Inserts fit all Industry Std. Tool Holders except Carbology®</p>	TNMC 32NV	8 tpi Max	.003 -.005	.375	S	S	S	LS	S	
	TNMC 43NV	6 tpi Max	.005 -.008	.500	S	S	LS	LS	S	
	TNMC 54NV	4 tpi Max	.005 -.008	.625	LS	LS	LS	LS	S	
	TNMC 64NV	4 tpi Max	.005 -.008	.750	LS	LS	LS	LS	LS	
	TNMC 66NV	3 tpi Max	.005 -.008	.750	LS	LS	LS	LS	LS	
Style:	Insert	Dimensions					Grades			
TPMC Positive Rake On Edge Threading	Description	PITCH	R	IC	C23	323FG	356FG	323	356	
 <p>* 10° Positive Rake TPMC Inserts fit all Industry Std. Tool Holders except Carbology®</p>	TPMC 32NV	8 tpi Max	.003 -.005	.375	S	S	LS	LS	S	
	TPMC 32NV-10 *	8 tpi Max	.003 -.005	.375	S	LS	LS	LS	LS	
	TPMC 43NV	6 tpi Max	.005 -.008	.500	S	S	LS	LS	S	
	TPMC 43NV-10 *	6 tpi Max	.005 -.008	.500	LS	LS	LS	LS	LS	
	TPMC 54NV	4 tpi Max	.005 -.008	.625	LS	LS	LS	LS	LS	
	TPMC 64NV	4 tpi Max	.005 -.008	.750	LS	LS	LS	LS	LS	
	TPMC 66NV	3 tpi Max	.005 -.008	.750	LS	LS	LS	LS	LS	
S = Stock Standard LS = Limited Stock or Non-Stock - Call for Availability										

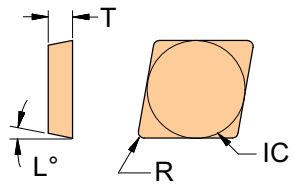
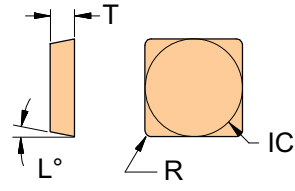
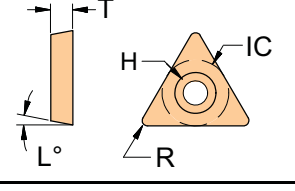
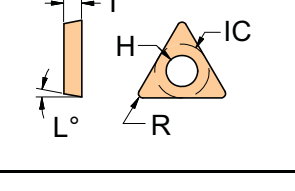
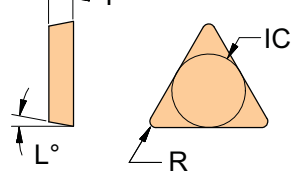
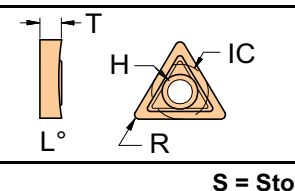
Style:	Insert	Dimensions						Grades				
ANSI - ISO Standards	Description	L	A	R	T	IC	H	C23	323FG	356FG	323	356
 <p>Additional Corner Radius Sizes Available On Request</p>	CPG 420	11°	80°	.004	.125	.500		S	S	LS	LS	LS
	CPG 420.5	11°	80°	.008	.125	.500		S	S	LS	LS	LS
	CPG 421	11°	80°	.016	.125	.500		S	S	S	LS	LS
	CPG 422	11°	80°	.031	.125	.500		S	S	S	LS	LS
	CPG 423	11°	80°	.047	.125	.500		S	S	LS	LS	LS
	CFG 4620	25°	80°	.004	.125	.464		S	S	LS	LS	LS
	CFG 4621	25°	80°	.016	.125	.464		S	S	LS	LS	LS
	CFG 4622	25°	80°	.031	.125	.464		S	S	LS	LS	LS
	SPG 420	11°	90°	.004	.125	.500		S	S	LS	LS	LS
	SPG 420.5	11°	90°	.008	.125	.500		S	S	LS	LS	LS
	SPG 421	11°	90°	.016	.125	.500		S	S	LS	LS	S
	SPG 422	11°	90°	.031	.125	.500		S	S	LS	LS	S
	SPG 423	11°	90°	.047	.125	.500		S	S	LS	LS	LS
	TD 6P R002	10°	60°	.002	.125	.375	.125	S	S	LS	LS	LS
	TD 6P R007	10°	60°	.007	.125	.375	.125	S	S	LS	LS	LS
	TD 6P R015	10°	60°	.015	.125	.375	.125	S	S	LS	LS	LS
	TD 6P	10°	60°	.031	.125	.375	.125	S	S	LS	LS	LS
	TP 40	10°	60°	.005	.094	.250	.137	S	S	LS	LS	LS
	TP 41	10°	60°	.016	.094	.250	.137	S	S	LS	LS	LS
	TP 42	10°	60°	.031	.094	.250	.137	S	S	LS	LS	LS
	TP 61	10°	60°	.016	.125	.375	.163	S	S	LS	LS	LS
	TP 62	10°	60°	.031	.125	.375	.163	S	S	LS	LS	LS
 <p>Additional Corner Radius Sizes Available On Request</p> <p>* TFG Inserts in Grade C23 Come with J Polished Tops</p>	TFG 320.5 J *	25°	60°	.008	.125	.375		LS	LS	LS	LS	LS
	TFG 321 J *	25°	60°	.016	.125	.375		S	LS	LS	LS	LS
	TFG 322 J *	25°	60°	.031	.125	.375		S	LS	LS	LS	LS
	TPG 221	11°	60°	.016	.125	.250		LS	LS	LS	LS	LS
	TPG 222	11°	60°	.031	.125	.250		LS	LS	LS	LS	LS
	TPG 320 R003	11°	60°	.003	.125	.375		S	S	LS	LS	LS
	TPG 320 R005	11°	60°	.005	.125	.375		S	S	S	LS	S
	TPG 320.5	11°	60°	.008	.125	.375		S	S	S	LS	LS
	TPG 321	11°	60°	.016	.125	.375		S	S	S	LS	S
	TPG 322	11°	60°	.031	.125	.375		S	S	S	LS	S
	TPG 323	11°	60°	.047	.125	.375		S	S	LS	LS	LS
	TPG 324	11°	60°	.062	.125	.375		S	S	S	LS	LS
	TPG 430	11°	60°	.004	.1875	.500		S	S	LS	LS	LS
	TPG 430.5	11°	60°	.008	.1875	.500		S	S	LS	LS	LS
	TPG 431	11°	60°	.016	.1875	.500		S	S	LS	LS	LS
TPG 432	11°	60°	.031	.1875	.500		S	S	LS	LS	LS	
TPG 433	11°	60°	.047	.1875	.500		S	S	LS	LS	LS	
	T221P	0°	60°	.016	.125	.250	.094	S	S	LS	LS	LS
	T321P	0°	60°	.016	.125	.375	.152	S	S	LS	LS	LS
For Kennametal® Tool Holders & Boring Bars												
S = Stock Standard LS = Limited Stock or Non-Stock - Call for Availability												

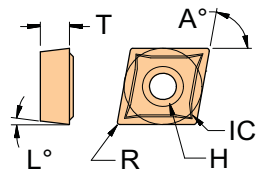
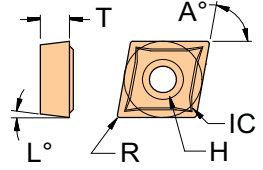
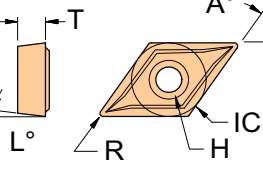
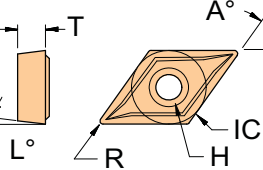
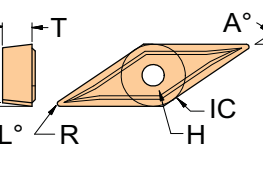
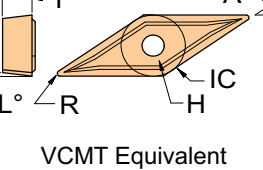
Style:	Insert	Dimensions						Grades				
		Description	L	A	R	T	IC	H	C23	323FG	356FG	323
 <p>CCMT Equivalent</p>	CCGT 21.50 .002	7°	80°	.002	.094	.250	.110	S	S	NA	LS	NA
	CCGT 21.50	7°	80°	.004	.094	.250	.110	S	S	S	LS	S
	CCGT 21.50.5	7°	80°	.008	.094	.250	.110	S	S	S	LS	S
	CCGT 21.51	7°	80°	.016	.094	.250	.110	S	S	S	LS	S
	CCGT 21.52	7°	80°	.031	.094	.250	.110	S	S	S	LS	S
	CCGT 32.50 .002	7°	80°	.002	.156	.375	.173	S	S	NA	LS	NA
	CCGT 32.50	7°	80°	.004	.156	.375	.173	S	S	S	LS	S
	CCGT 32.50.5	7°	80°	.008	.156	.375	.173	S	S	S	LS	S
	CCGT 32.51	7°	80°	.016	.156	.375	.173	S	S	S	LS	S
	CCGT 32.52	7°	80°	.031	.156	.375	.173	S	S	S	LS	S
 <p>CPGM - CPMT Equivalent</p>	CPGT 21.50 .002	11°	80°	.002	.094	.250	.110	S	S	NA	LS	NA
	CPGT 21.50	11°	80°	.004	.094	.250	.110	S	S	S	LS	S
	CPGT 21.50.5	11°	80°	.008	.094	.250	.110	S	S	S	LS	S
	CPGT 21.51	11°	80°	.016	.094	.250	.110	S	S	S	LS	S
	CPGT 21.52	11°	80°	.031	.094	.250	.110	S	S	S	LS	S
	CPGT 32.50 .002	11°	80°	.002	.156	.375	.173	S	S	NA	LS	NA
	CPGT 32.50	11°	80°	.004	.156	.375	.173	S	S	S	LS	S
	CPGT 32.50.5	11°	80°	.008	.156	.375	.173	S	S	S	LS	S
	CPGT 32.51	11°	80°	.016	.156	.375	.173	S	S	S	LS	S
	CPGT 32.52	11°	80°	.031	.156	.375	.173	S	S	S	LS	S
 <p>DCMT Equivalent</p>	DCGT 21.50	7°	55°	.004	.094	.250	.110	S	S	NA	LS	NA
	DCGT 21.50.5	7°	55°	.008	.094	.250	.110	S	S	LS	LS	LS
	DCGT 21.51	7°	55°	.016	.094	.250	.110	S	S	LS	LS	LS
	DCGT 21.52	7°	55°	.031	.094	.250	.110	S	S	LS	LS	LS
	DCGT 32.50	7°	55°	.004	.156	.375	.173	S	S	NA	LS	NA
	DCGT 32.50.5	7°	55°	.008	.156	.375	.173	S	S	LS	LS	LS
	DCGT 32.51	7°	55°	.016	.156	.375	.173	S	S	LS	LS	LS
DCGT 32.52	7°	55°	.031	.156	.375	.173	S	S	LS	LS	LS	
 <p>DPMT Equivalent</p>	DPGT 21.50	11°	55°	.004	.094	.250	.110	LS	LS	NA	LS	NA
	DPGT 21.50.5	11°	55°	.008	.094	.250	.110	S	S	LS	LS	LS
	DPGT 21.51	11°	55°	.016	.094	.250	.110	S	S	LS	LS	LS
	DPGT 21.52	11°	55°	.031	.094	.250	.110	S	S	LS	LS	LS
	DPGT 32.50	11°	55°	.004	.156	.375	.173	S	S	NA	LS	NA
	DPGT 32.50.5	11°	55°	.008	.156	.375	.173	S	S	LS	LS	LS
	DPGT 32.51	11°	55°	.016	.156	.375	.173	S	S	LS	LS	LS
DPGT 32.52	11°	55°	.031	.156	.375	.173	S	S	LS	LS	LS	
 <p>VBMT Equivalent</p>	VBGT 220.5	5°	35°	.008	.125	.250	.110	S	S	LS	LS	LS
	VBGT 221	5°	35°	.016	.125	.250	.110	S	S	LS	LS	LS
	VBGT 222	5°	35°	.031	.125	.250	.110	S	S	LS	LS	LS
	VBGT 330	5°	35°	.004	.1875	.375	.173	S	S	LS	LS	LS
	VBGT 330.5	5°	35°	.008	.1875	.375	.173	S	S	LS	LS	LS
	VBGT 331	5°	35°	.016	.1875	.375	.173	S	S	LS	LS	LS
	VBGT 332	5°	35°	.031	.1875	.375	.173	S	S	LS	LS	LS
 <p>VCMT Equivalent</p>	VCGT 220.5	7°	35°	.008	.125	.250	.110	S	S	LS	LS	LS
	VCGT 221	7°	35°	.016	.125	.250	.110	S	S	LS	LS	LS
	VCGT 222	7°	35°	.031	.125	.250	.110	S	S	LS	LS	LS
	VCGT 330	7°	35°	.004	.1875	.375	.173	S	S	LS	LS	LS
	VCGT 330.5	7°	35°	.008	.1875	.375	.173	S	S	LS	LS	LS
	VCGT 331	7°	35°	.016	.1875	.375	.173	S	S	LS	LS	LS
	VCGT 332	7°	35°	.031	.1875	.375	.173	S	S	LS	LS	LS

S = Stock Standard LS = Limited Stock or Non-Stock - Call for Availability

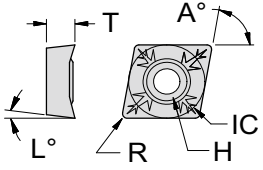
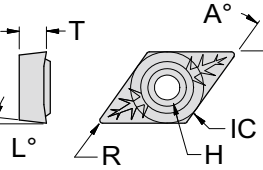
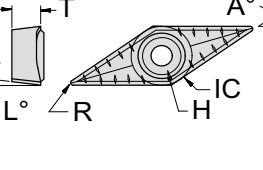
Style:	Insert	Dimensions						Grades	
ANSI-ISO High Positive Rake For Aluminum	Description	L	A	R	T	IC	H	C23J	323F
 <p>25° Positive Rake Chipbreaker</p>	CCGT 21.50.5-25P CCGT 060202FN-25P	7°	80°	.008	.094	.250	.110	S	S
	CCGT 21.51-25P CCGT 060204FN-25P	7°	80°	.016	.094	.250	.110	S	S
	CCGT 09T301FN-25P CCGT 32.50-25P	7°	80°	.004	.156	.375	.173	S	S
	CCGT 09T302FN-25P CCGT 32.50.5-25P	7°	80°	.008	.156	.375	.173	S	S
	CCGT 09T304FN-25P CCGT 32.51-25P	7°	80°	.016	.156	.375	.173	S	S
	CCGT 09T308FN-25P CCGT 32.52-25P	7°	80°	.031	.156	.375	.173	S	S
	CCGT 430.5-25P CCGT 120402FN-25P	7°	80°	.008	.1875	.500	.216	S	S
	CCGT 431-25P CCGT 120404FN-25P	7°	80°	.016	.1875	.500	.216	S	S
	CCGT 432-25P CCGT 120408FN-25P	7°	80°	.031	.1875	.500	.216	S	S
 <p>25° Positive Rake Chipbreaker</p>	DCGT 21.50.5-25P DCGT 070202FN-25P	7°	55°	.008	.094	.250	.110	S	LS
	DCGT 21.51-25P DCGT 070204FN-25P	7°	55°	.016	.094	.250	.110	S	LS
	DCGT 32.50.5-25P DCGT 11T302FN-25P	7°	55°	.008	.156	.375	.173	S	S
	DCGT 32.51-25P DCGT 11T304FN-25P	7°	55°	.016	.156	.375	.173	S	S
	DCGT 32.52-25P DCGT 11T308FN-25P	7°	55°	.031	.156	.375	.173	S	S
 <p>25° Positive Rake Chipbreaker</p>	VCGT 220.5-25P VCGT 110302FN-25P	7°	35°	.008	.125	.250	.110	S	LS
	VCGT 221-25P VCGT 110304FN-25P	7°	35°	.016	.125	.250	.110	S	LS
	VCGT 331-25P VCGT 160404FN-25P	7°	35°	.016	.1875	.375	.216	S	S
	VCGT 332-25P VCGT 160408FN-25P	7°	35°	.031	.1875	.375	.216	S	S
<p>Polished High Positive Rake Grade C23J Inserts are Designed for Aluminum, Copper and Plastics Use TiALN Coated Grade 323F for Finishing Most Materials Including Stainless, Titanium & Hardened Steels 45Rc +</p>									
<p>S = Stock Standard LS = Limited Stock or Non-Stock - Call for Availability</p>									

Style:	Insert	Dimensions						Grades				
ANSI - ISO Standards	Description	L	A	R	T	IC	H	C23	C23J	323FG	323	356
<p>10° Double Positive Rake for Finishing & Light Roughing</p>	CNGP 430K .002	0°	80°	.002	.1875	.500	.203	LS	LS	LS	LS	NA
	CNGP 430K	0°	80°	.004	.1875	.500	.203	S	S	S	LS	NA
	CNGP 430.5K	0°	80°	.008	.1875	.500	.203	S	S	S	LS	NA
	CNGP 431K	0°	80°	.016	.1875	.500	.203	S	S	S	LS	NA
	CNGP 432K	0°	80°	.031	.1875	.500	.203	S	S	S	LS	NA
	CNGP 433K	0°	80°	.047	.1875	.500	.203	S	S	S	S	NA
<p>10° Positive Rake for Titanium & High Temperature Alloys</p>	CNGG 430	0°	80°	.004	.1875	.500	.203	S	S	S	LS	NA
	CNGG 430.5	0°	80°	.008	.1875	.500	.203	S	S	S	LS	NA
	CNGG 431	0°	80°	.016	.1875	.500	.203	S	S	S	LS	NA
	CNGG 432	0°	80°	.031	.1875	.500	.203	S	S	S	LS	NA
	CNGG 433	0°	80°	.047	.1875	.500	.203	S	S	S	LS	NA
<p>2 Sided Insert for Finishing and Light Roughing</p>	DNGP 430 K	0°	55°	.004	.1875	.500	.203	S	S	S	LS	NA
	DNGP 430.5 K	0°	55°	.008	.1875	.500	.203	S	S	S	LS	NA
	DNGP 431 K	0°	55°	.016	.1875	.500	.203	S	S	S	LS	NA
	DNGP 432 K	0°	55°	.031	.1875	.500	.203	S	S	S	LS	NA
	DNGP 433 K	0°	55°	.047	.1875	.500	.203	S	S	S	S	NA
<p>2 Sided Light Finishing Insert</p>	VNGP 330 K	0°	35°	.004	.1875	.375	.150	NA	S	S	LS	NA
	VNGP 330.5 K	0°	35°	.008	.1875	.375	.150	NA	S	S	LS	NA
	VNGP 331 K	0°	35°	.016	.1875	.375	.150	NA	S	S	S	NA
<p>2 Sided General Purpose Insert</p>	VNGP 330 D	0°	35°	.004	.1875	.375	.150	S	S	S	LS	NA
	VNGP 330.5 D	0°	35°	.008	.1875	.375	.150	S	S	S	LS	LS
	VNGP 331 D	0°	35°	.016	.1875	.375	.150	S	S	S	LS	S
	VNGP 332 D	0°	35°	.031	.1875	.375	.150	S	S	S	S	NA
<p>10° Double Positive Rake for Finishing & Light Roughing</p>	WNGP 430 K	0°	80°	.004	.1875	.500	.203	S	S	S	LS	NA
	WNGP 430.5 K	0°	80°	.008	.1875	.500	.203	S	S	S	LS	NA
	WNGP 431 K	0°	80°	.016	.1875	.500	.203	S	S	S	LS	NA
	WNGP 432 K	0°	80°	.031	.1875	.500	.203	S	S	S	LS	S

S = Stock Standard LS = Limited Stock or Non-Stock - Call for Availability

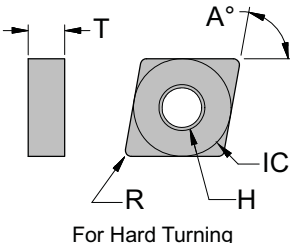
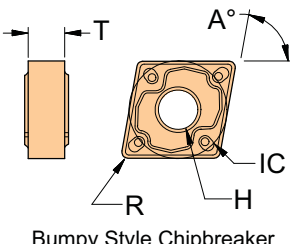
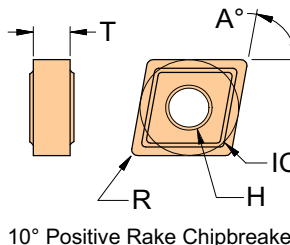
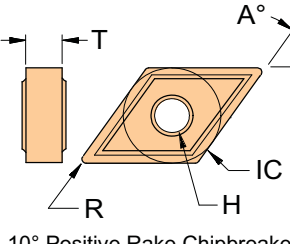
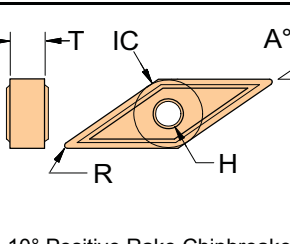
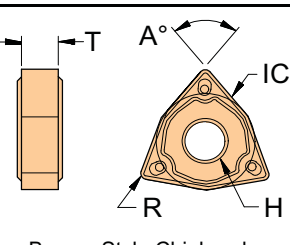
Style:	Insert	Dimensions					Grades			
Flat Top - No Chipbreaker	Description	A	R	T	IC	H	C23	323FG	323	623
 <p>For Hard Turning</p>	CNMA 432	80°	.031	.1875	.500	.203	LS	LS	LS	S
	CNMA 433	80°	.047	.1875	.500	.203	LS	LS	LS	S
CVD Aluminum Oxide Coated Grade 623 for Turning Hard Materials Over 50Rc Run at 100 SFM, .005 to .020 Depth of Cut and Feed Rate under .005										
Style:	Insert	Dimensions					Grades			
ANSI - ISO Standards	Description	A	R	T	IC	H	C23	323FG	323	323F
 <p>Bumpy Style Chipbreaker</p>	CNMG 432GP	80°	.031	.1875	.500	.203	LS	LS	LS	LS
	For Light Roughing 300 Series Stainless, 15-5PH, 17-4PH, A286 and other Tough To Machine Alloys at Moderate Feeds & Speeds									
 <p>10° Positive Rake Chipbreaker</p>	CNMG 432HT	80°	.031	.1875	.500	.203	LS	LS	LS	LS
	For Light Roughing in Titanium, Inconel® and other High Temperature Alloys HT Style Chipbreakers Provide Chip Control in Tough, Gummy Materials									
 <p>10° Positive Rake Chipbreaker</p>	DNMG 431HT	55°	.016	.1875	.500	.203	LS	LS	LS	LS
	DNMG 432HT	55°	.031	.1875	.500	.203	LS	LS	LS	LS
For Light Roughing in Titanium, Inconel® and other High Temperature Alloys HT Style Chipbreakers Provide Chip Control in Tough, Gummy Materials										
 <p>10° Positive Rake Chipbreaker</p>	VNMG 331HT	35°	.016	.1875	.375	.150	LS	LS	LS	LS
	VNMG 332HT	35°	.031	.1875	.375	.150	LS	LS	LS	LS
For Light Roughing in Titanium, Inconel® and other High Temperature Alloys HT Style Chipbreakers Provide Chip Control in Tough, Gummy Materials										
 <p>Bumpy Style Chipbreaker</p>	WNMG 432GP	80°	.031	.1875	.500	.203	LS	LS	LS	LS
	For Light Roughing 300 Series Stainless, 15-5PH, 17-4PH, A286 and other Tough To Machine Alloys at Moderate Feeds & Speeds									

S = Stock Standard

LS = Limited Stock or Non-Stock - Call for Availability

PROFILING INSERTS

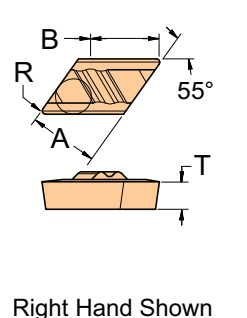
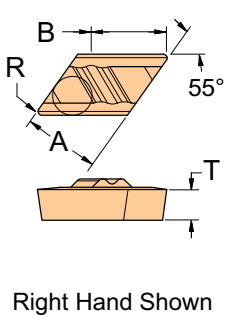
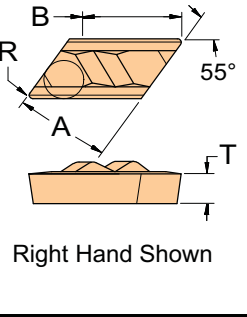
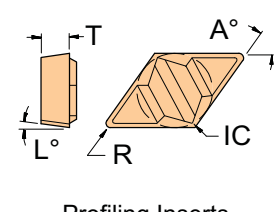
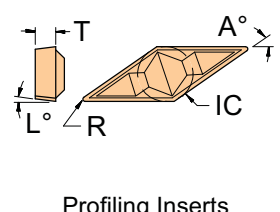
Style:	Insert Description		Dimensions					Grades					
HPR/L Profiling	Right Hand	Left Hand	A	R	T	B	IC	C23	C23J	323FG	356FG	323	356
 <p>Right Hand Shown</p>	HPR 50 R002		.365	.002	.125	.254	.250	S	S	S	NA	LS	NA
		HPL 50 R002						S	S	S	NA	LS	NA
	HPR 50.5		.375	.005	.125	.263	.250	S	S	S	S	LS	S
		HPL 50.5						S	S	S	S	LS	S
	HPR 50.8		.375	.008	.125	.260	.250	S	S	S	LS	LS	LS
		HPL 50.8						S	S	S	LS	LS	LS
	HPR 51		.375	.016	.125	.253	.250	S	S	S	S	LS	S
		HPL 51						S	S	S	S	LS	S
 <p>Right Hand Shown</p>	HPR 130.5		.500	.005	.188	.321	.375	S	S	S	LS	LS	LS
		HPL 130.5						S	S	S	LS	LS	LS
	HPR 130.8		.500	.008	.188	.318	.375	S	S	S	LS	LS	LS
		HPL 130.8						S	S	S	LS	LS	LS
	HPR 131F		.500	.016	.188	.311	.375	S	S	S	S	LS	S
		HPL 131F						LS	LS	LS	LS	LS	LS
	HPR 132F		.500	.031	.188	.297	.375	S	S	S	S	LS	S
		HPL 132F						S	S	S	LS	LS	LS
 <p>Right Hand Shown</p>	HPR 331N		.733	.016	.188	.595	.375	LS	LS	LS	LS	LS	LS
		HPL 331N						LS	LS	LS	LS	LS	LS
	HPR 332F		.733	.031	.188	.581	.375	LS	LS	S	LS	LS	LS
		HPL 332F						LS	LS	LS	LS	LS	LS
	HPR 332N		.733	.031	.188	.581	.375	LS	LS	LS	LS	LS	LS
		HPL 332N						LS	LS	S	LS	LS	LS
	HPR 332		.733	.031	.188	.581	.375	LS	LS	S	LS	LS	LS
		HPL 332						LS	LS	S	LS	LS	LS
Style:	Insert		Dimensions					Grades					
DPGR - VPGR	Description		A	R	T	L	IC	C23	323FG	356FG	323	356	
 <p>Profiling Inserts</p>	DPGR 430		55°	.004	.188	8°	.500	S	S	NA	LS	NA	
	DPGR 430.5		55°	.008	.188	8°	.500	S	S	LS	LS	LS	
	DPGR 431		55°	.016	.188	8°	.500	S	S	LS	LS	LS	
	DPGR 432		55°	.031	.188	8°	.500	S	S	LS	LS	LS	
 <p>Profiling Inserts</p>	VPGR 330		35°	.004	.188	8°	.375	S	S	NA	LS	NA	
	VPGR 330.5		35°	.008	.188	8°	.375	S	S	LS	LS	LS	
	VPGR 331		35°	.016	.188	8°	.375	S	S	LS	LS	LS	
	VPGR 332		35°	.031	.188	8°	.375	S	S	LS	LS	LS	

S = Stock Standard LS = Limited Stock or Non-Stock - Call for Availability

Notch Style Threading & Grooving Tool Holders

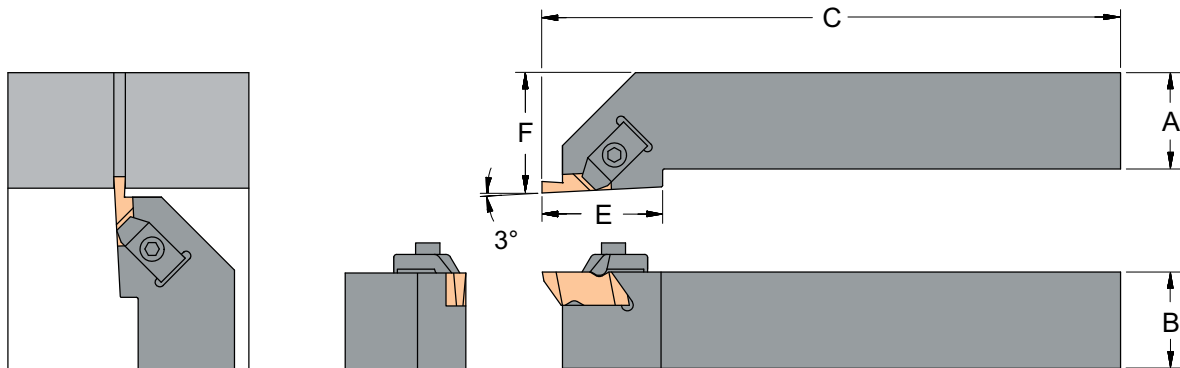

Right Hand Shown

Holder Description		Dimensions						Parts	
Right Hand	Left Hand	Insert Size Grooving - Threading	A	B	C	E	F	Clamp	Screw
TSR-62		HG 2xxxR - HT 2R	.375	.375	2.500	.750	.562	CM-74	S-310
	TSL-62	HG 2xxxL - HT 2L						CM-75	
TSR-82		HG 2xxxR - HT 2R	.500	.500	3.500	.750	.750	CM-74	S-310
	TSL-82	HG 2xxxL - HT 2L						CM-75	
TSR-102B		HG 2xxxR - HT 2R	.625	.625	4.500	.750	.875	CM-74	S-310
	TSL-102B	HG 2xxxL - HT 2L						CM-75	
TSR-122B		HG 2xxxR - HT 2R	.750	.750	4.500	.750	1.000	CM-74	S-310
	TSL-122B	HG 2xxxL - HT 2L						CM-75	
TSR-162C		HG 2xxxR - HT 2R	1.000	1.000	5.000	.750	1.250	CM-74	S-310
	TSL-162C	HG 2xxxL - HT 2L						CM-75	
TSR-123B		HG 3xxxR - HT 3R	.750	.750	4.500	1.250	1.000	CM-72	S-412
	TSL-123B	HG 3xxxL - HT 3L						CM-73	
TSR-163C		HG 3xxxR - HT 3R	1.000	1.000	5.000	1.250	1.250	CM-72	S-412
	TSL-163C	HG 3xxxL - HT 3L						CM-73	
TSR-163D		HG 3xxxR - HT 3R	1.000	1.000	6.000	1.250	1.250	CM-72	S-412
	TSL-163D	HG 3xxxL - HT 3L						CM-73	
TSR-203D		HG 3xxxR - HT 3R	1.250	1.250	6.000	1.380	1.500	CM-72	S-412
	TSL-203D	HG 3xxxL - HT 3L						CM-73	
TSR-164D		HG 4xxxR - HT 4R	1.000	1.000	6.000	1.250	1.250	CM-72	S-412
	TSL-164D	HG 4xxxL - HT 4L						CM-73	
TSR-204D		HG 4xxxR - HT 4R	1.250	1.250	6.000	1.500	1.500	CM-72	S-412
	TSL-204D	HG 4xxxL - HT 4L						CM-73	
TSR-244D		HG 4xxxR - HT 4R	1.500	1.500	6.000	1.500	2.000	CM-72	S-412
	TSL-244D	HG 4xxxL - HT 4L						CM-73	

Call for Availability

Notch Style 90° Face Grooving & ID Threading-Grooving Holders

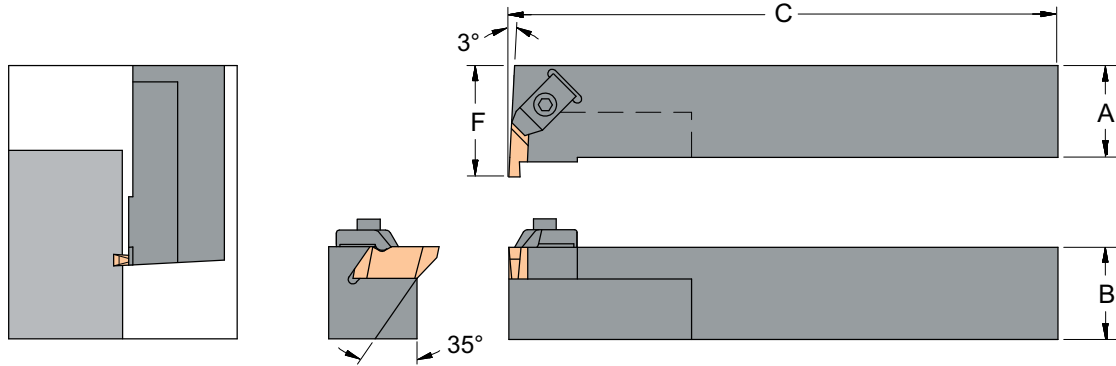

Right Hand Shown - Use Left Hand Inserts In 90° Right Hand Face Grooving Holders

Holder Description		Dimensions					Parts	
Right Hand	Left Hand	Insert Size Face - ID Grooving	A	B	C	F	Clamp	Screw
TER 163D		HF / HG 3xxxL	1.000	1.000	6.000	1.250	CM-73	S-412
	TEL 163D	HF / HG 3xxxR					CM-72	
TER 164D		HF / HG 4xxxL	1.000	1.000	6.000	1.375	CM-73	S-412
	TEL 164D	HF / HG 4xxxR					CM-72	

Notch Style Carbide Shank ID Threading & Grooving Bars

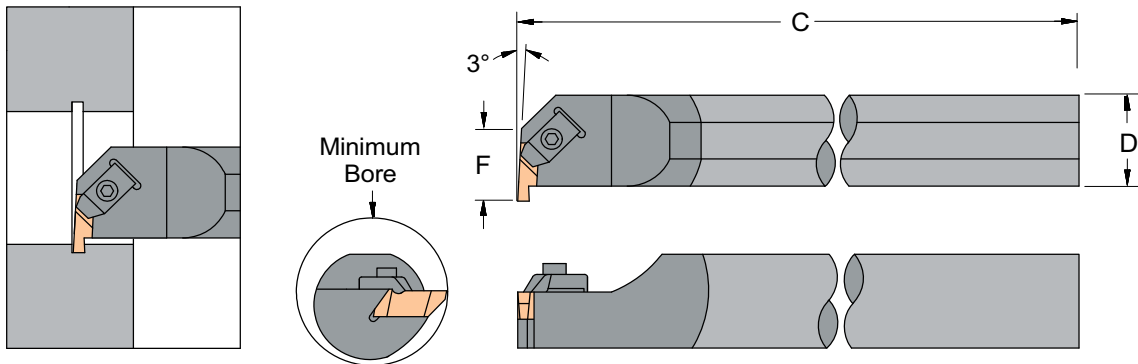

Right Hand Shown - Use Left Hand Inserts In Right Hand Boring Bars

Bar Description		Dimensions					Parts	
Right Hand	Left Hand	Insert Size Grooving - Threading	D	Min Bore	C	F	Clamp	Screw
C08-TER2		HG 2xxxL - HT 2L	.500	0.730	6.000	.437	CM-147	S-39
	C08-TEL2	HG 2xxxR - HT 2R					CM-146	
C10-TER2		HG 2xxxL - HT 2L	.625	1.000	8.000	.500	CM-75	S-310
	C10-TEL2	HG 2xxxR - HT 2R					CM-74	
C12-TER2		HG 2xxxL - HT 2L	.750	1.125	10.000	.562	CM-75	S-310
	C12-TEL2	HG 2xxxR - HT 2R					CM-74	
C16-TER2		HG 2xxxL - HT 2L	1.000	1.375	12.000	.688	CM-75	S-310
	C16-TEL2	HG 2xxxR - HT 2R					CM-74	
C16-TER3		HG 3xxxL - HT 3L	1.000	1.375	12.000	.688	CM-73	S-412
	C16-TEL3	HG 3xxxR - HT 3R					CM-72	

Call for Availability

Notch Style Steel ID Threading & Grooving Bars With Through Coolant Holes

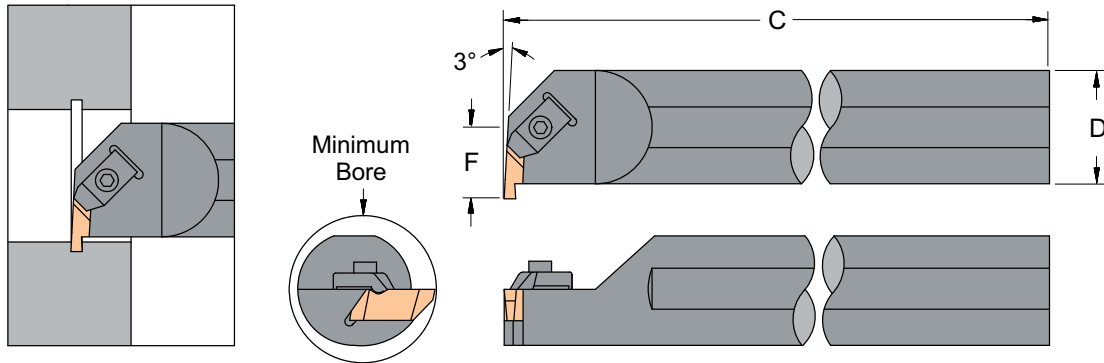

Right Hand Shown - Use Left Hand Inserts In Right Hand Boring Bars

* Please Note: Minimum Bore Diameter for Horizon Size 2 Deep Grooving Inserts

Bar Description		Dimensions						Parts	
Right Hand	Left Hand	Insert Size Grooving - Threading	D	Min Bore	Min Bore Deep *	C	F	Clamp	Screw
A08-TER2		HG 2xxxL - HT 2L	.500	.730	1.075	6.000	.437	CM-147	S-39
	A08-TEL2	HG 2xxxR - HT 2R						CM-146	
A10-TER2		HG 2xxxL - HT 2L	.625	1.000	1.200	8.000	.500	CM-75	S-310
	A10-TEL2	HG 2xxxR - HT 2R						CM-74	
A12-TER2		HG 2xxxL - HT 2L	.750	1.125	1.325	10.000	.562	CM-75	S-310
	A12-TEL2	HG 2xxxR - HT 2R						CM-74	
A16-TER2		HG 2xxxL - HT 2L	1.000	1.375	1.575	12.000	.688	CM-75	S-310
	A16-TEL2	HG 2xxxR - HT 2R						CM-74	
A16-TER3		HG 3xxxL - HT 3L	1.000	1.375		12.000	.688	CM-73	S-412
	A16-TEL3	HG 3xxxR - HT 3R						CM-72	
A20-TER3		HG 3xxxL - HT 3L	1.250	1.750		14.000	.875	CM-73	S-412
	A20-TEL3	HG 3xxxR - HT 3R						CM-72	
A24-TER3		HG 3xxxL - HT 3L	1.500	2.000		14.000	1.000	CM-73	S-412
	A24-TEL3	HG 3xxxR - HT 3R						CM-72	
A28-TER3		HG 3xxxL - HT 3L	1.750	2.250		14.000	1.125	CM-73	S-412
	A28-TEL3	HG 3xxxR - HT 3R						CM-72	
A32-TER3		HG 3xxxL - HT 3L	2.000	2.500		14.000	1.250	CM-73	S-412
	A32-TEL3	HG 3xxxR - HT 3R						CM-72	

NOTE: These Boring Bars come with Through Coolant Holes
 Boring Bars without Coolant Holes are available in some sizes. Please call for Availability.

Solid Carbide Thread Mill Identification System

TM N 1/2 x .470 - 14 UN - T2

TM	N	1/2	.470	14	UN	T2 *
Denotes Thread Mill	N=Internal E=External X=Internal Or External	Denotes Shank Diameter in Common Fractions	Denotes Tool Cutter Diameter in Thousandths Of An Inch	Denotes Pitch In Threads Per Inch, ISO Pitch In mm	Denotes Thread Form Type	Denotes Distance In Pitch Form Each Tooth

* This Position Omitted For Standard Length Solid Carbide Mills

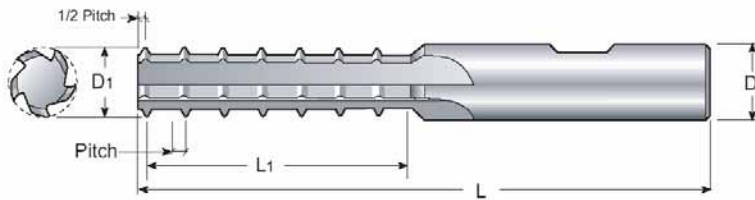

UN Internal Threads T2 Long Length

Min. Size Thread*	Tool Description	Pitch	Flutes	D	D1	L	L1	Grades	
								323FG	323F
# 4-40	TMN 1/8 x .080 - 40 UN-T2	40	3	.125	.085	1.5	.2500	70800	78800
#6-32	TMN 1/8 x .085 - 32 UN-T2	32	3	.125	.085	1.5	.2500	70801	78801
#8-32	TMN 1/8 x .120 - 32 UN-T2	32	3	.125	.120	1.5	.3750	70802	78802
1/4"-28	TMN 3/16 x .160 - 28 UN-T2	28	3	.188	.160	2.56	.5000	70813	78813
1/4"-28	TMN 1/4 x .180 - 28 UN-T2	28	3	.250	.180	2.95	.7857	70814	78814
#10-24	TMN 1/8 x .120 - 24 UN-T2	24	3	.125	.120	1.5	.2500	70821	78821
#12-24	TMN 3/16 x .140 - 24 UN-T2	24	3	.187	.140	2.56	.5000	70815	78815
5/16"-24	TMN 1/4 x .200 - 24 UN-T2	24	3	.250	.200	2.95	.8333	70816	78816
3/8"-24	TMN 1/4 x .240 - 24 UN-T2	24	5	.250	.240	2.95	.8333	70822	78822
1/4"-20	TMN 3/16 x .160 - 20 UN-T2	20	3	.187	.160	2.56	.5000	70803	78803
7/16"-20	TMN 5/16 x .310 - 20 UN-T2	20	5	.313	.310	3.35	1.0000	70817	78817
5/16"-18	TMN 1/4 x .200 - 18 UN-T2	18	3	.250	.200	2.95	.6667	70804	78804
5/8"-18	TMN 1/2 x .437 - 18 UN-T2	18	5	.500	.437	3.94	1.4444	70819	78819
3/8"-16	TMN 1/4 x .240 - 16 UN-T2	16	5	.250	.240	2.95	.7500	70805	78805
11/16"-16	TMN 1/2 x .470 - 16 UN-T2	16	5	.500	.470	3.94	1.6250	70820	78820
7/16"-14	TMN 5/16 x .310 - 14 UN-T2	14	5	.313	.310	3.35	.8571	70806	78806
1/2"-13	TMN 5/16 x .310 - 13 UN-T2	13	5	.313	.310	3.35	1.0769	70807	78807
9/16"-12	TMN 3/8 x .370 - 12 UN-T2	12	5	.375	.370	3.35	1.3333	70808	78808
3/4"-12	TMN 1/2 x .470 - 12 UN-T2	12	5	.500	.470	3.94	1.5000	70818	78818
5/8"-11	TMN 1/2 x .437 - 11 UN-T2	11	5	.500	.437	3.94	1.4545	70809	78809
3/4"-10	TMN 1/2 x .470 - 10 UN-T2	10	5	.500	.470	3.94	1.6000	70810	78810
7/8"-9	TMN 5/8 x .620 - 9 UN-T2	9	6	.625	.620	4.10	1.7778	70811	78811
1"-8	TMN 5/8 x .620 - 8 UN-T2	8	6	.625	.620	4.10	2.0000	70812	78812
1-1/8"-7	TMN 5/8 x .620 - 7 UN-T2	7	6	.625	.620	4.10	2.0000	70823	78823

UN Internal
Std. Length
Thread Mills

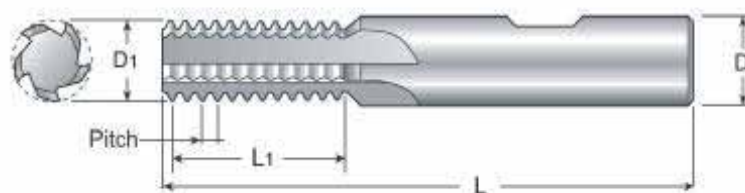

Long, Extra Long
and Metric Sizes
Available on Request

Min. Size Thread*	Tool Description	Pitch	Flutes	D	D1	L	L1	Grades	
								323FG	323F
9/16"-12	TMN 3/8 x .370 - 12 UN	12	5	.375	.370	2.84	.875	70123	78123
3/4"-12	TMN 1/2 x .470 - 12 UN	12	5	.500	.470	3.27	1.1253	70124	78124
5/8"-11	TMN 3/8 x .370 - 11 UN	11	5	.375	.370	2.84	.8636	70125	78125
5/8"-11	TMN 1/2 x .437 - 11 UN	11	5	.500	.437	3.27	1.0455	70126	78126
3/4"-10	TMN 1/2 x .470 - 10 UN	10	5	.500	.470	3.27	1.050	70127	78127
7/8"-9	TMN 5/8 x .620 - 9 UN	9	6	.625	.620	3.62	1.3333	70128	78128
1"-8	TMN 5/8 x .620 - 8 UN	8	6	.625	.620	3.62	1.5000	70129	78129
1-1/8"-7	TMN 5/8 x .620 - 7 UN	7	6	.625	.620	3.62	1.4286	70130	78130
1-3/8"-6	TMN 3/4 x .745 - 6 UN	6	6	.750	.745	4.10	1.5000	70131	78131
1-3/4"-5	TMN 3/4 x .745 - 5 UN	5	6	.750	.745	4.10	1.4000	70132	78132
2"-4.5	TMN 3/4 x .745 - 4.5 UN	4.5	6	.750	.745	4.10	1.4000	70133	78133

NPT
Internal / External
Thread Mills

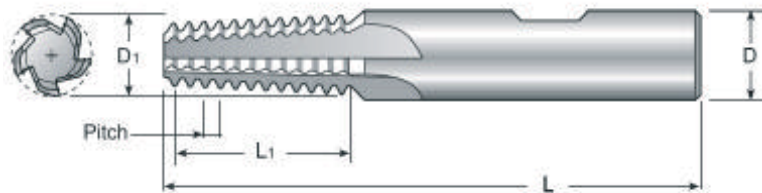

NPT Internal / External Thread Mills

Minimum Size*	Tool Description	Pitch	Flutes	D	D1	L	L1	Grades	
								323FG	323F
1/16 & 1/8 NPT	TMX 1/4 x .240-27NPT	27	5	.250	.240	2.25	.351	70300	78300
1/4 & 3/8 NPT	TMX 5/16 x .310-18NPT	18	5	.312	.310	2.48	.527	70301	78301
1/2 & 3/4 NPT	TMX 1/2 x .470-14NPT	14	5	.500	.470	3.27	.749	70302	78302
1" - 2" NPT	TMX 5/8 x .620-11.5NPT	11.5	6	.625	.620	3.62	1.007	70303	78303
2 1/2" - 6" NPT	TMX 5/8 x .620-8NPT	8	6	.625	.620	3.62	1.188	70304	78304
2 1/2" - 6" NPT	TMX 3/4 x .745-8NPT	8	6	.750	.745	4.10	1.438	70305	78305

NPTF Dryseal / Straight Pipe Thread Mills

Minimum Size*	Tool Description	Pitch	Flutes	D	D1	L	L1	Grades	
								323FG	323F
1/16 & 1/8 NPTF	TMX 1/4 x .240-27NPTF	27	5	.250	.240	2.25	.351	70306	78306
1/4 & 3/8 NPTF	TMX 5/16 x .310-18NPTF	18	5	.312	.310	2.48	.527	70307	78307
1/2 & 3/4 NPTF	TMX 1/2 x .470-14NPTF	14	5	.500	.470	3.27	.749	70308	78308
1" - 2" NPTF	TMX 5/8 x .620-11.5NPTF	11.5	6	.625	.620	3.62	1.007	70309	78309
2 1/2" - 6" NPTF	TMX 5/8 x .620-8NPTF	8	6	.625	.620	3.62	1.188	70310	78310
2 1/2" - 6" NPTF	TMX 5/8 x .620-8NPTF	8	6	.625	.620	3.62	1.188	70311	78311

323FG - General Purpose TIN Coated C2-C6 (K20-P20) Grade For Most Thread Milling Applications
323F - High Performance TiAlN Coated C2-C7 (K20-K15) Grade for Higher Speeds & Longer Tool Life

Contact Horizon Carbide for additional information and Programming Recommendations
Please Call For Thread Mill Pricing and Availability

NPSM
Internal Pipe Threads
(Straight Pipe Mechanical internal)

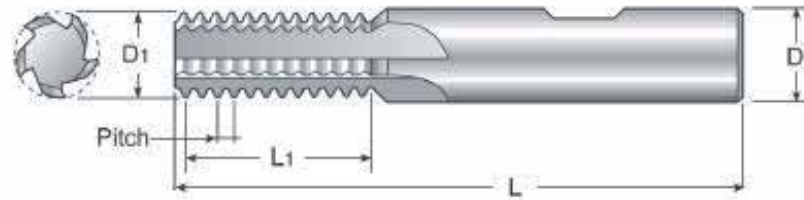

Minimum Size*	Tool Description	Pitch	Flutes	D	D1	L	L1	Grades	
								323FG	323F
1/16 & 1/8 NPSM	TMX 1/4 x .240-27NPSM	27	5	.250	.240	2.25	.5926	70318	78318
1/4 & 3/8 NPSM	TMX 5/16 x .310-18NPSM	18	5	.312	.310	2.48	.7222	70319	78319
1/2 & 3/4 NPSM	TMX 1/2 x .470-14NPSM	14	5	.500	.470	3.27	1.1428	70320	78320
1" - 2" NPSM	TMX 5/8 x .620-11.5NPSM	11.5	6	.625	.620	3.62	1.3913	70321	78321
2 1/2" - 6" NPSM	TMX 5/8 x .620-8NPSM	8	6	.625	.620	3.62	1.2500	70322	78322
2 1/2" - 6" NPSM	TMX 3/4 x .745-8NPSM	8	6	.750	.745	4.10	1.5000	70323	78323

NPSF
(DRYSEAL) Pipe Threads Straight Pipe
Internal/External

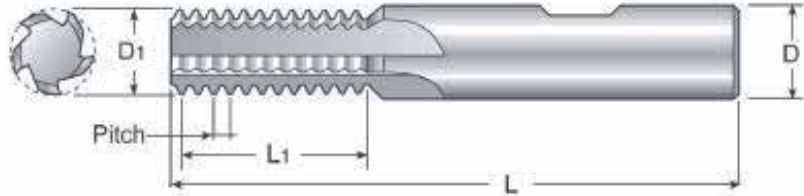

Minimum Size*	Tool Description	Pitch	Flutes	D	D1	L	L1	Grades	
								323FG	323F
1/16 & 1/8 NPSF	TMX 1/4 x .240-27NPSF	27	5	.250	.240	2.25	2.25	70312	78312
1/4 & 3/8 NPSF	TMX 5/16 x .310-18NPSF	18	5	.312	.310	2.48	2.48	70313	78313
1/2 & 3/4 NPSF	TMX 1/2 x .470-14NPSF	14	5	.500	.470	3.27	3.27	70314	78314
1" - 2" NPSF	TMX 5/8 x .620-11.5NPSF	11.5	6	.625	.620	3.62	3.62	70315	78315
2 1/2" - 6" NPSF	TMX 5/8 x .620-8NPSF	8	6	.625	.620	3.62	3.62	70316	78316
2 1/2" - 6" NPSF	TMX 3/4 x .745-8NPSF	8	6	.750	.745	4.10	4.10	70317	78317

BSPT
British Standard Pipe Taper
Internal / External

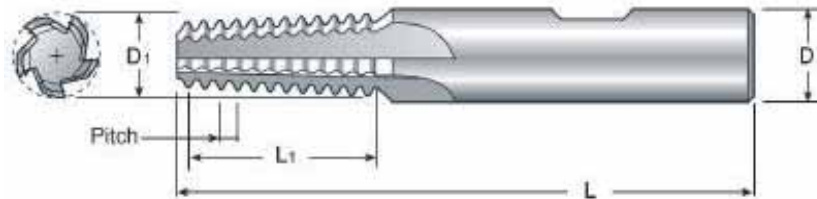

Minimum Size*	Tool Description	Pitch	Flutes	D	D1	L	L1	Grades	
								323FG	323F
R1/16 - R1/8 BSPT	TMX 1/4 x .240-28BSPT	27	5	.250	.240	2.25	.3928	70328	78328
R1/4 - R3/8 BSPT	TMX 5/16 x .310-19BSPT	18	5	.312	.310	2.48	.5789	70329	78329
R1/2 - R3/4 BSPT	TMX 1/2 x .470-14BSPT	14	5	.500	.470	3.27	.7857	70330	78330
R1" - R2" BSPT	TMX 5/8 x .620-11BSPT	11.5	6	.625	.620	3.62	1.5454	70331	78331

323FG - General Purpose TIN Coated C2-C6 (K20-P20) Grade For Most Thread Milling Applications
323F - High Performance TiALN Coated C2-C7 (K20-K15) Grade for Higher Speeds & Longer Tool Life

Contact Horizon Carbide for additional information and Programming Recommendations
 Please Call For Thread Mill Pricing and Availability

BSP
British Straight Pipe
Internal / External

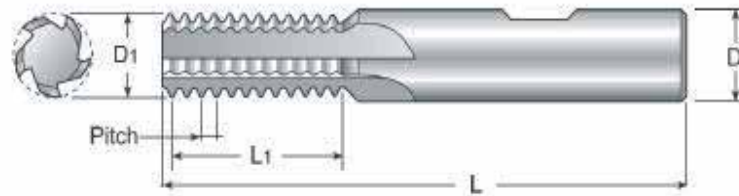

Minimum Size*	Tool Description	Pitch	Flutes	D	D1	L	L1	Grades	
								323FG	323F
G1/16 - G1/8 BSP	TMX 1/4 x .240-28 BSP	28	5	.250	.240	2.25	.5714	70328	78328
G1/4 - G3/8 BSP	TMX 5/16 x .310-19 BSP	19	5	.312	.310	2.48	.7368	70329	78329
G1/2 - G3/4 BSP	TMX 1/2 x .470-14 BSP	14	5	.500	.470	3.27	1.1428	70330	78330
G1" -G2" BSP	TMX 5/8 x .620-11 BSP	11	6	.625	.620	3.62	1.3636	70331	78331

ISO
Metric Internal Threads
Standard Length

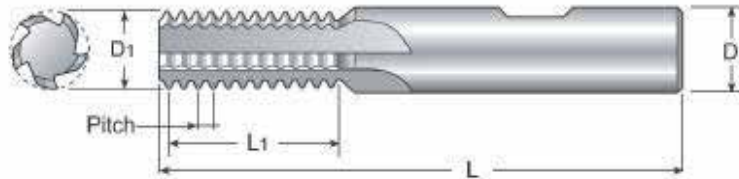

Minimum Size*	Tool Description	Pitch	Flutes	D	D1	L	L1	Grades	
								323FG	323F
M 1.6	TMN 1/8 x .040 - 0.35 ISO	0.35	3	.125	.040	1.500	.0959	70400	78400
M 2	TMN 1/8 x .050 - 0.40 ISO	0.40	3	.125	.050	1.500	.1260	70401	78401
M 2.5	TMN 1/8 x .060 - 0.45 ISO	0.45	3	.125	.060	1.500	.1417	70402	78402
M 3	TMN 1/8 x .085 - 50 ISO	0.50	3	.125	.085	1.500	.1772	70403	78403
M 4	TMN 1/8 x .105 - 0.70 ISO	0.70	3	.125	.105	1.500	.2657	70404	78404
M 4.5	TMN 1/8 x .120 - 0.75 ISO	0.75	3	.125	.120	1.50	.2657	70405	78405
M 8	TMN 1/4 x .240 - 0.75 ISO	0.75	5	.250	.240	2.25	.5906	70406	78406
M 5	TMN 3/16 x .145 - 0.80 ISO	0.80	3	.187	.145	1.65	.3149	70407	78407
M 6	TMN 3/16 x .160 - 1.00 ISO	1.00	3	.187	.160	1.65	.3543	70408	78408
M 10	TMN 1/4 x .240 - 1.00 ISO	1.00	5	.250	.240	2.25	.5906	70424	78424
M 12	TMN 5/16 x .310 - 1.00 ISO	1.00	5	.312	.310	2.48	.7874	70409	78409
M 16	TMN 1/2 x .470 - 1.00 ISO	1.00	5	.500	.470	3.27	1.1811	70410	78410
M 8	TMN 1/4 x .200 - 1.25 ISO	1.25	3	.250	.200	2.25	.4921	70411	78411
M 10	TMN 1/4 x .240 - 1.50 ISO	1.50	5	.250	.240	2.25	.5906	70412	78412
M 14	TMN 3/8 x .370 - 1.50 ISO	1.50	5	.375	.370	2.84	.9449	70413	78413
M 18	TMN 1/2 x .470 - 1.50 ISO	1.50	5	.312	.310	2.48	.7578	70414	78414
M 12	TMN 5/16 x .310 - 1.75 ISO	1.75	5	.312	.310	2.48	.7578	70415	78415
M 14	TMN 3/8 x .370 - 2.00 ISO	2.00	5	.375	.370	2.84	.9449	70416	78416
M 16	TMN 1/2 x .437 - 2.00 ISO	2.00	5	.500	.437	3.27	1.1811	70425	78425
M 18	TMN 1/2 x .470 - 2.00 ISO	2.00	5	.500	.470	3.27	1.1811	70417	78417
M 20	TMN 1/2 x .470 - 2.5 ISO	2.50	5	.500	.470	3.27	1.1811	70418	78418
M 24	TMN 5/8 x .620 - 3.00 ISO	3.00	6	.625	.620	3.62	1.4173	70419	78419
M 30	TMN 5/8 x .620 - 3.50 ISO	3.50	6	.625	.620	3.62	1.5157	70420	78420
M 36	TMN 5/8 x .620 - 4.00 ISO	4.00	6	.625	.620	3.62	1.5748	70421	78421
M 48	TMN 3/4 x .745 - 5.00 ISO	5.00	6	.750	.745	4.10	1.5748	70422	78422
M 64	TMN 3/4 x .745 - 6.00 ISO	6.00	6	.750	.745	4.10	1.4173	70423	78423

*Minimum Size: The smallest internal thread size that can be cut with a specific Thread Mill. All of the Tools above can be used to cut larger diameter threads than the nominal size as long as the L1 dimension exceeds the full thread length. For adequate chip clearance, tool diameter should not exceed 70% of the Minor Thread Diameter. For best results use the largest diameter tool that meets these requirements. Contact Horizon Carbide Tool for additional information and Programming Recommendations.

SOLID CARBIDE THREAD MILLS 38

ISO Metric
External Threads
Standard Length

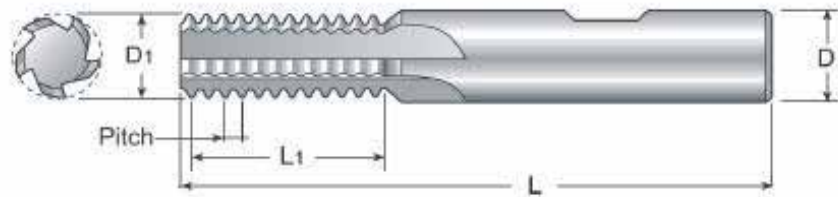

Min. Size Thread*	Tool Description	Pitch	Flutes	D	D1	L	L1	Grades	
								323FG	323F
ALL 0.50 ISO	TME 1/4 x .240 - 0.50 ISO	0.50	5	.250	.240	2.25	.5906	70500	78500
ALL 0.75 ISO	TME 5/16 x .310 - 0.75 ISO	0.75	5	.312	.310	2.48	.7677	70501	78501
ALL 1.00 ISO	TME 3/8 x .370 - 1.00 ISO	1.00	5	.375	.370	2.84	.9449	70502	78502
ALL 1.50 ISO	TME 1/2 x .470 - 1.50 ISO	1.50	5	.500	.470	3.27	1.1811	70503	78503
ALL 2.00 ISO	TME 1/2 x .470 - 2.00 ISO	2.00	5	.500	.470	3.62	1.4173	70504	78504
ALL 3.00 ISO	TME 5/8 x .620 - 3.00 ISO	3.00	6	.625	.620	3.62	1.4173	70505	78505
ALL 4.00 ISO	TME 5/8 x .620 - 4.00 ISO	4.00	6	.625	.620	3.62	1.5748	70506	78506
ALL 5.00 ISO	TME 3/4 x .745 - 6.00 ISO	6.00	6	.750	.745	4.10	1.4173	70507	78507

UN External Threads Standard Length

Min. Size Thread*	Tool Description	Pitch	Flutes	D	D1	L	L1	Grades	
								323FG	323F
ALL 36 UN	TME 1/4 x .240 - 36 UN	36	5	.250	.240	2.25	.2778	70208	78208
ALL 32 UN	TME 1/4 x .240 - 32 UN	32	5	.250	.240	2.25	.5625	70200	78200
ALL 32 UN	TME 3/8 x .370 - 32 UN	32	5	.375	.370	2.84	.9375	70209	78209
ALL 28 UN	TME 5/16 x .310 - 28 UN	28	5	.312	.310	2.48	.7857	70201	78201
ALL 24 UN	TME 5/16 x .310 - 24 UN	24	5	.312	.310	2.48	.7917	70210	78210
ALL 24 UN	TME 3/8 x .370 - 24 UN	24	5	.375	.370	2.84	1.0000	70211	78211
ALL 20 UN	TME 3/8 x .370 - 20 UN	20	5	.375	.370	2.84	.9000	70202	78202
ALL 18 UN	TME 3/8 x .370 - 18 UN	18	5	.375	.370	2.84	.9444	70203	78203
ALL 16 UN	TME 1/2 x .470 - 16 UN	16	5	.500	.470	3.27	1.1250	70204	78204
ALL 14 UN	TME 5/16 x .310 - 14 UN	14	5	.312	.310	2.48	1.6429	70212	78212
ALL 14 UN	TME 1/2 x .470 - 14 UN	14	5	.500	.470	3.27	1.1429	70213	78213
ALL 12 UN	TME 1/2 x .470 - 12 UN	12	5	.500	.470	3.27	1.1670	70205	78205
ALL 8 UN	TME 5/8 x .620 - 8 UN	8	6	.625	.620	3.62	1.5000	70206	78206
ALL 6 UN	TME 3/4 x .745 - 6 UN	6	6	.750	.745	4.10	1.5000	70207	78207

UNJ External Threads Standard Length

Min. Size Thread*	Tool Description	Pitch	Flutes	D	D1	L	L1	Grades	
								323FG	323F
ALL 32 UNJ	TME 1/4 x .240 - 32 UNJ	32	5	.250	.240	2.25	.5313	71000	71800
ALL 24 UNJ	TME 3/8 x .370 - 24 UNJ	24	5	.375	.370	2.84	.9583	71001	71801
ALL 20 UNJ	TME 3/8 x .370 - 20 UNJ	20	5	.375	.370	2.84	.9000	71002	71802
ALL 18 UNJ	TME 5/16 x .310 - 18 UNJ	18	5	.312	.310	2.48	.7778	71003	71803
ALL 18 UNJ	TME 1/2 x .470 - 18 UNJ	18	5	.500	.470	3.27	1.1111	71004	71804
ALL 16 UNJ	TME 5/16 x .310 - 16 UNJ	16	5	.312	.310	2.48	1.0000	71005	71805
ALL 16 UNJ	TME 1/2 x .470 - 16 UNJ	16	5	.500	.470	3.27	1.1250	71006	71806
ALL 14 UNJ	TME 1/2 x .470 - 14 UNJ	14	5	.500	.470	3.27	1.1428	71007	71807
ALL 12 UNJ	TME 1/2 x .470 - 12 UNJ	12	5	.500	.470	3.27	1.1667	71008	71808

ISO Metric
Internal Threads T2 Long

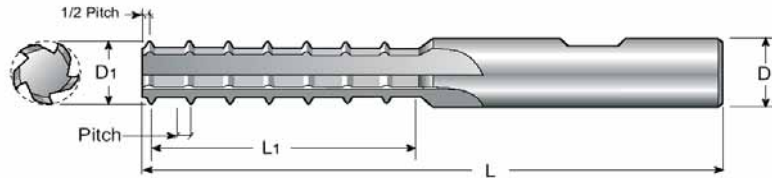

Min. Size Thread*	Tool Description	Pitch	Flutes	D	D1	L	L1	Grades	
								323FG	323F
M 4	TMN 1/8 x .105 - 0.70 ISO-T2	0.70	3	.125	0.105	1.500	.3307	70850	78850
M 8	TMN 1/4 x .240 - 0.75 ISO-T2	0.75	5	.250	.240	2.95	.7677	70859	78859
M 5	TMN 3/16 x .145 - 0.80 ISO-T2	0.80	3	.187	.145	2.56	.4409	70851	78851
M 6	TMN 3/16 x .160 - 1.00 ISO-T2	1.00	3	.187	.160	2.56	.4724	70852	78852
M 12	TMN 5/16 x .310 - 1.00 ISO-T2	1.00	5	.312	.310	3.35	.9445	70860	78860
M 16	TMN 1/2 x .470 - 1.00 ISO-T2	1.00	5	.500	.470	3.94	1.8110	70861	78861
M 8	TMN 1/4 x .200 - 1.25 ISO-T2	1.25	3	.250	.200	2.95	.7874	70853	78853
M 10	TMN 1/4 x .240 - 1.50 ISO-T2	1.50	5	.250	.240	2.95	.8267	70854	78854
M 14	TMN 3/8 x .370 - 1.50 ISO-T2	1.50	5	.370	.370	3.35	1.2992	70862	78862
M 18	TMN 1/2 x .470 - 1.50 ISO-T2	1.50	5	.500	.470	3.94	1.5354	70863	78863
M 12	TMN 5/16 x .310 - 1.75 ISO-T2	1.75	5	.312	.310	3.35	.9646	70855	78855
M 14	TMN 3/8 x .370 - 2.00 ISO-T2	2.00	5	.375	.370	3.35	1.4173	70856	78856
M 16	TMN 1/2 x .437 - 2.00 ISO-T2	2.00	5	.500	.437	3.94	1.4173	70857	78857
M 18	TMN 1/2 x .470 - 2.00 ISO-T2	2.00	5	.500	.470	3.94	1.5748	70864	78864
M 20	TMN 1/2 x .470 - 2.50 ISO-T2	2.50	5	.500	.470	3.94	1.5748	70858	78858
M 24	TMN 5/8 x .620 - 3.00 ISO-T2	3.00	6	.625	.620	4.10	1.8897	70865	78865

ISO Metric Internal Threads T3 Long Length

Min. Size Thread*	Tool Description	Pitch	Flutes	D	D1	L	L1	Grades	
								323FG	323F
M 4	TMN 1/8 x .105 - 0.70 ISO-T3	0.70	3	.125	0.105	1.500	.4960	70950	78950
M 8	TMN 1/4 x .240 - 0.75 ISO-T3	0.75	5	.250	.240	2.95	.9744	70959	78959
M 5	TMN 3/16 x .145 - 0.80 ISO-T3	0.80	3	.187	.145	2.56	6.772	70951	78951
M 6	TMN 3/16 x .160 - 1.00 ISO-T3	1.00	3	.187	.160	2.56	.7087	70952	78952
M 12	TMN 5/16 x .310 - 1.00 ISO-T3	1.00	5	.312	.310	3.35	.9449	70960	78960
M 16	TMN 1/2 x .470 - 1.00 ISO-T3	1.00	5	.500	.470	3.94	2.0079	70961	78961
M 8	TMN 1/4 x .200 - 1.25 ISO-T3	1.25	3	.250	.200	2.95	1.0335	70953	78953
M 10	TMN 1/4 x .240 - 1.50 ISO-T3	1.50	5	.250	.240	2.95	1.0630	70954	78954
M 14	TMN 3/8 x .370 - 1.50 ISO-T3	1.50	5	.370	.370	3.35	1.5945	70962	78962
M 18	TMN 1/2 x .470 - 1.50 ISO-T3	1.50	5	.500	.470	3.94	1.9488	70963	78963
M 12	TMN 5/16 x .310 - 1.75 ISO-T3	1.75	5	.312	.310	3.35	1.4469	70955	78955
M 14	TMN 3/8 x .370 - 2.00 ISO-T3	2.00	5	.375	.370	3.35	1.6535	70956	78956
M 16	TMN 1/2 x .437 - 2.00 ISO-T3	2.00	5	.500	.437	3.94	1.8897	70957	78957
M 18	TMN 1/2 x .470 - 2.00 ISO-T3	2.00	5	.500	.470	3.94	1.8897	70964	78964
M 20	TMN 1/2 x .470 - 2.50 ISO-T3	2.50	5	.500	.470	3.94	1.8700	70958	78958

*Minimum Size: The smallest internal thread size that can be cut with a specific Thread Mill. All of the Tools above can be used to cut larger diameter threads than the nominal size as long as the L1 dimension exceeds the full thread length. For adequate chip clearance, tool diameter should not exceed 70% of the Minor Thread Diameter. For best results use the largest diameter tool that meets these requirements. Contact Horizon Carbide Tool for additional information and Programming Recommendations.

UN Internal
Std. Length
Thread Mills

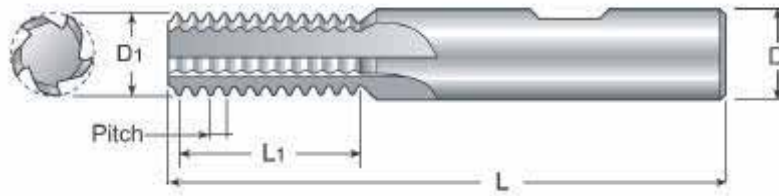

Long, Extra Long
and Metric Sizes
Available on Request

Min. Size Thread*	Tool Description	Pitch	Flutes	D	D1	L	L1	Grades	
								323FG	323F
# 2-64	TMN 1/8 x .060 - 64 UN	64	3	.125	.060	1.500	.1172	70100	78100
# 2-56	TMN 1/8 x .060 - 56 UN	56	3	.125	.060	1.500	.1161	70101	78101
# 3-48	TMN 1/8 x .060 - 48 UN	48	3	.125	.060	1.500	.1354	70102	78102
# 5-44	TMN 1/8 x .085 - 44 UN	44	3	.125	.085	1.500	.1705	70103	78103
# 4-40	TMN 1/8 x .080 - 40 UN	40	3	.125	.080	1.500	.1625	70138	78138
5/16"-40	TMN 1/4 x .240 - 40 UN	40	5	.250	.240	2.250	.3625	70142	78142
# 8-36	TMN 1/8 x .120 - 36 UN	36	3	.125	.120	1.500	.2361	70105	78105
# 6-32	TMN 1/8 x .085 - 32 UN	32	3	.125	.085	1.500	.2031	70106	78106
# 8-32	TMN 1/8 x .120 - 32 UN	32	3	.125	.120	1.500	.2344	70107	78107
# 10-32	TMN 3/16 x .140 - 32 UN	32	3	.187	.140	1.650	.2969	70143	78143
7/16"-32	TMN 1/4 x .240 - 32 UN	32	5	.250	.240	2.250	.5469	70108	78108
1/2"-32	TMN 3/8 x .370 - 32 UN	32	5	.375	.370	2.840	.9531	70139	78139
#12-28	TMN 3/16 x .145 - 28 UN	28	3	.187	.145	1.650	.3036	70109	78109
5/16"-28	TMN 1/4 x .240 - 28 UN	28	5	.250	.240	2.250	.5535	70144	78144
7/16"-28	TMN 5/16 x .310 - 28 UN	28	5	.312	.310	2.480	.7679	70110	78110
7/16"-27	TMN 5/16 x .310 - 27 UN	27	5	.312	.310	2.480	.7593	70145	78145
#12-24	TMN 3/16 x .140 - 24 UN	24	3	.187	.140	1.650	.3125	70140	78140
1/4"-24	TMN 3/16 x .160 - 24 UN	24	3	.187	.160	1.650	.3125	70111	78111
5/16"-24	TMN 1/4 x .200 - 24 UN	24	3	.250	.200	2.250	.4792	70112	78112
3/8"-24	TMN 1/4 x .240 - 24 UN	24	5	.250	.240	2.250	.5625	70135	78135
1/2"-24	TMN 3/8 x .370 - 24 UN	24	5	.375	.370	2.840	.6875	70136	78136
1/4"-20	TMN 3/16 x .160 - 20 UN	20	3	.187	.160	1.650	.375	70113	78113
5/16"-20	TMN 1/4 x .187 - 20 UN	20	3	.250	.187	2.250	.475	70137	78137
7/16"-20	TMN 5/16 x .310 - 20 UN	20	5	.312	.310	2.480	.725	70114	78114
9/16"-20	TMN 3/8 x .370 - 20 UN	20	5	.375	.370	2.840	.875	70115	78115
5/8"-20	TMN 1/2 x .470 - 20 UN	20	5	.500	.470	3.270	.975	70141	78141
5/16"-18	TMN 1/4 x .200 - 18 UN	18	3	.250	.200	2.250	.4722	70116	78116
9/16"-18	TMN 3/8 x .370 - 18 UN	18	5	.375	.370	2.840	.9167	70117	78117
5/8"-18	TMN 1/2 x .437 - 18 UN	18	5	.500	.437	3.270	1.0833	70134	78134
3/8"-16	TMN 1/4 x .240 - 16UN	16	5	.250	.240	2.250	.5313	70118	78118
13/16"-16	TMN1/2 x .470 - 16 UN	16	5	.500	.470	3.270	1.0938	70119	78119
7/16"-14	TMN 5/16 x .310 - 14 UN	14	5	.312	.310	2.480	.6071	70120	78120
1/2"-14	TMN 3/8 x .370 - 14 UN	14	5	.375	.370	2.840	.8929	70146	78146
7/8"-14	TMN 1/2 x .470 - 14 UN	14	5	.500	.470	3.270	1.1071	70121	78121
1/2"-13	TMN 5/16 x .310 - 13 UN	13	5	.375	.310	2.480	.7308	70122	78122

*Minimum Size: The smallest internal thread size that can be cut with a specific Thread Mill. All of the Tools above can be used to cut larger diameter threads than the nominal size as long as the L1 dimension exceeds the full thread length. For adequate chip clearance, tool diameter should not exceed 70% of the Minor Thread Diameter. For best results use the largest diameter tool that meets these requirements. Contact Horizon Carbide Tool for additional information and Programming Recommendations.

**UN
Internal Threads T3
Extra Long Length**

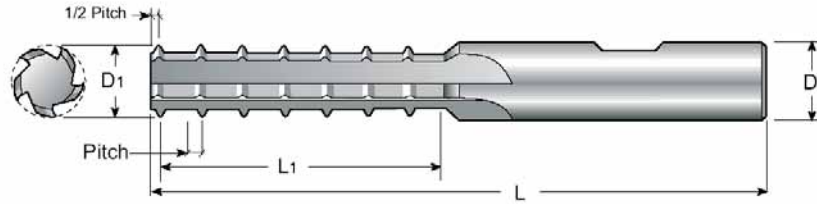

Min. Size Thread*	Tool Description	Pitch	Flutes	D	D1	L	L1	Grades	
								323FG	323F
# 4-40	TMN 1/8 x .080 - 40 UN-T3	40	3	.125	.080	1.5	.3750	70900	78900
#6-32	TMN 1/8 x .085 - 32 UN-T3	32	3	.125	.085	1.5	.3750	70901	78901
#8-32	TMN 1/8 x .120 - 32 UN-T3	32	3	.125	.120	1.5	.4688	70902	78902
#12-28	TMN 3/16 x .160 - 28 UN-T3	28	3	.187	.160	2.56	.7500	70913	78913
1/4"-28	TMN 1/4 x .180 - 28 UN-T3	28	3	.250	.180	2.56	.7500	70914	78914
#10-24	TMN 1/8 x .120 - 24 UN-T3	24	3	.125	.120	1.5	.3750	70921	78921
#12-24	TMN 3/16 x .140 - 24 UN-T3	24	3	.187	.140	2.56	.6250	70915	78915
5/16"-24	TMN 1/4 x .200 - 24 UN-T3	24	3	.250	.200	2.95	1.0000	70916	78916
3/8"-24	TMN 1/4 x .240 - 24 UN-T3	24	5	.250	.240	2.95	1.0000	70920	78920
1/4"-20	TMN 3/16 x .160 - 20 UN-T3	20	3	.187	.160	2.56	.7500	70903	78903
7/16"-20	TMN 5/16 x .310 - 20 UN-T3	20	5	.312	.310	3.35	1.2000	70917	78917
5/16"-18	TMN 1/4 x .200 - 18 UN-T3	18	3	.250	.200	2.95	1.0000	70904	78904
3/8"-16	TMN 1/4 x .240 - 16 UN-T3	16	5	.250	.240	2.95	1.1250	70905	78905
7/16"-14	TMN 5/16 x .310 - 14 UN-T3	14	5	.312	.310	3.35	1.2857	70906	78906
1/2"-13	TMN 5/16 x .310 - 13 UN-T3	13	5	.312	.310	3.35	1.3847	70907	78907
9/16"-12	TMN 3/8 x .370 - 12 UN-T3	12	5	.375	.370	3.35	1.5000	70908	78908
3/4"-12	TMN 1/2 x .470 - 12 UN-T3	12	5	.500	.470	3.94	2.0000	70918	78918
5/8"-11	TMN 1/2 x .437 - 11 UN-T3	11	5	.500	.437	3.94	1.9090	70909	78909
3/4"-10	TMN 1/2 x .470 - 10 UN-T3	10	5	.500	.470	3.94	2.1000	70910	78910
7/8"-9	TMN 5/8 x .620 - 9 UN-T3	9	6	.625	.620	4.10	2.0000	70911	78911
1"-8	TMN 5/8 x .620 - 8 UN-T3	8	6	.625	.620	4.10	1.8750	70912	78912
1-1/8"-7	TMN 5/8 x .620 - 7 UN-T3	7	6	.625	.620	4.10	2.1428	70919	78919

323FG - General Purpose TIN Coated C2-C6 (K20-P20) Grade For Most Thread Milling Applications

323F - High Performance TiAlN Coated C2-C7 (K20-K15) Grade for Higher Speeds & Longer Tool Life

Contact Horizon Carbide for additional information and Programming Recommendations

Please Call For Thread Mill Pricing and Availability

***Minimum Size: The smallest internal thread size that can be cut with a specific Thread Mill.**

All of the Tools above can be used to cut larger diameter threads than the nominal size as long as the L1 dimension exceeds the full thread length. For adequate chip clearance, tool diameter should not exceed 70% of the Minor Thread Diameter. For best results use the largest diameter tool that meets these requirements. Contact Horizon Carbide Tool for additional information and Programming Recommendations.

Recommended Speeds & Feeds For Turning & Grooving With Horizon Carbide Inserts							
Material Group	Material Specs.	Surface Speeds (SFM) & Feed Rates (FPR)					
		Uncoated	PVD TIN Coated		PVD TIALN Coated		
		C23 & C23J	323FG	356FG	310	323 & 323F	356
Aluminum	2024, 6061, 7075 etc.	Maximum SFM .001-.010+ FPR	Maximum SFM .001-.010+ FPR	Maximum SFM .001-.010+ FPR	---	---	---
Aluminum - Cast	A356 (A380, A390 Use Diamond)	600-1000 .001-.010+ FPR	800-1000 .001-.010+ FPR	---	---	---	---
Copper	Most Alloys	600-1000 .001-.007 FPR	800-1000 .001-.007 FPR	---	---	---	---
Brass - Bronze	Most Free Machining Alloys	600-1000 .001-.010 FPR	800-1000 .001-.010 FPR	---	---	---	---
Carbon Steels - Soft	1010, 1018, 1025 1117, 12L14	---	300-500 .001-.005 FPR	400-600 .001-.008 FPR	200-300 .001-.008 FPR	300-600 .001-.005 FPR	450-850 .001-.008 FPR
Carbon Steels 25 Rc+	1045, 1070, 1144, A36	---	300-450 .001-.005 FPR	350-550 .001-.006 FPR	200-300 .001-.007 FPR	300-500 .001-.005 FPR	450-750 .001-.007 FPR
Alloy Steels	4130, 4140, 4330 4340, 8620	---	250-450 .001-.004 FPR	350-500 .001-.005 FPR	200-300 .001-.006 FPR	300-500 .001-.004 FPR	400-700 .001-.006 FPR
Alloy Steels 30 Rc+	4130, 4140, 4150 4330, 4340, 52100	---	250-450 .001-.004 FPR	300-500 .001-.005 FPR	200-300 .001-.005 FPR	300-450 .001-.004 FPR	350-600 .001-.005 FPR
Tool Steels - Annealed	O1, W1, S6, P20 A6, D2, H13, etc.	---	200-400 .001-.004 FPR	250-450 .001-.004 FPR	150-300 .001-.004 FPR	200-400 .001-.004 FPR	350-600 .001-.005 FPR
Stainless Steels	201, 202, 301, 302 303, 304, 410, 416	---	250-450 .001-.003 FPR	250-500 .001-.004 FPR	200-300 .001-.005 FPR	300-600 .001-.004 FPR	350-500 .001-.005 FPR
Stainless Steels	304L, 316, 316L, 420 422, 430, 455, 17-4PH	---	200-400 .001-.003 FPR	225-450 .001-.004 FPR	150-275 .001-.004 FPR	250-550 .001-.003 FPR	250-450 .001-.005 FPR
Stainless Steels	316VAR, 13-8MO PH 15-5 PH 36 Rc+, 440C	---	150-300 .001-.003 FPR	---	150-250 .001-.003 FPR	150-350 .001-.003 FPR	150-300 .001-.004 FPR
Titanium - CP	Commercially Pure	150-400 .001-.006 FPR	250-400 .001-.003 FPR	---	200-300 .001-.003 FPR	250-600 .001-.003 FPR	---
Titanium - Alloys	6AL-4V, 5AL-2.5SN	100-200 .001-.003 FPR	100-200 .001-.003 FPR	---	100-250 .001-.003 FPR	150-350 .001-.003 FPR	---
Titanium - Hardened	Alloys 36 Rc+	75-100 .001-.003 FPR	75-125 .001-.003 FPR	---	75-150 .001-.003 FPR	100-200 .001-.003 FPR	---
High Temp Alloys	Ni 200, Monel, Invar Kovar, Inconel 600	100-150 .001-.003 FPR	100-200 .001-.003 FPR	---	100-250 .001-.003 FPR	100-300 .001-.003 FPR	---
High Temp Alloys	A286, Inconel 625 718, X750, Hastelloy	75-150 .001-.003 FPR	100-150 .001-.003 FPR	---	75-200 .001-.003 FPR	100-200 .001-.003 FPR	---
High Temp Alloys	Hardened Alloys 35 Rc+, Stellite etc.	50-100 .001-.002 FPR	50-125 .001-.002 FPR	---	50-100 .001-.002 FPR	75-150 .001-.003 FPR	---
Core Iron	Low Carbon Iron & Soft Iron Alloys	---	300-500 .001-.004 FPR	300-600 .001-.005 FPR	200-300 .001-.005 FPR	300-600 .001-.005 FPR	450-800 .001-.006 FPR
Gray Cast Iron	150-325 BHN Class 20, 30, 35, 40	200-300 .001-.010+ FPR	200-600 .001-.010+ FPR	---	100-300 .001-.010+ FPR	250-600 .001-.010+ FPR	---
Gray Cast Iron	275-450 BHN Class 50, 55, 60	150-250 .001-.008+ FPR	150-450 .001-.008+ FPR	---	100-250 .001-.008+ FPR	200-500 .001-.008+ FPR	---
Alloy / Ductile Iron	60-40-18, 80-55-06 100-70-03, A536	100-250 .001-.008+ FPR	150-500 .001-.008+ FPR	300-500 .001-.008+ FPR	100-300 .001-.008+ FPR	250-500 .001-.008+ FPR	300-600 .001-.008+ FPR

Horizon Carbide Grades are Designed to provide Long Tool Life at Higher Speeds and Light Feed Rates.

- 1. Start near the top of the SFM Range using a Light Feed Rate to Reduce Built-up Edge & Insert Chipping.**
- 2. Adjust RPM & Feeds after Setup to achieve Optimum Tool Life. Use Higher Feed Rates in Soft Materials.**
- 3. In Hard Materials Use a Wear Resistant Grade like 323 or 323F at Medium to Low SFM and Light Feeds.**

Formula to Calculate Surface Feet Per Minute (SFM): $SFM = 3.1416 \times \text{Part Diameter, Divided by } 12 \times \text{RPM}$

Recommended Speeds (SFM) For Threading With Horizon Carbide Inserts							
Material Group	Material Specs.	C23	323FG	356FG	310	323 & 323F	356
Aluminum	2024, 6061, 7075	Maximum SFM	Maximum SFM	Maximum SFM	---	---	---
Copper, Brass, Bronze	Most Alloys	200-600	300-800	---	---	---	---
Low Carbon Steels	1018, 1025, 1117, 12L14	---	300-500	40 0-650	200-300	300-600	450-750
Medium Carbon Steels	1045, 1070, 1144,	---	300-450	350-600	200-300	300-500	450-700
Alloy Steels	4130, 4140, 8620	---	250-450	350-550	200-300	300-500	400-650
Alloy Steels 28 Rc+	4150, 4340, 52100	---	250-400	300-500	200-275	300-450	350-600
Stainless Steels	303, 304, 410, 416	---	225-400	250-350	200-300	250-450	250-500
Stainless Steels	316, 316L, 422, 17-4PH	---	200-375	200-300	150-275	225-400	225-450
Titanium - CP	Commercially Pure	150-300	200-400	---	200-300	250-500	---
Titanium - Alloys	6AL-4V, 5AL-2.5SN	100-200	100-225	---	100-250	150-275	---
Nickel / Cobalt Alloys	Monel, Invar, Kovar	100-250	100-300	---	100-300	100-300	---
High Temp Alloys	Inconel, Hastelloy, A286	75-150	100-150	---	75-200	100-200	---
Cast Iron 150-325 BHN	Class 20, 30, 35, 40	200-300	200-600	---	100-300	250-600	---
Cast Iron 375-450 BHN	Class 50, 55, 60	150-250	150-450	---	100-250	200-500	---
Alloy / Ductile Iron	60-40-18, 80-55-06	100-250	150-400	200-400	100-300	250-450	300-500

Threading Guidelines For CNC Lathes

1. Start near the top of the SFM range for the material being threaded.

Higher SFM reduces Built-up Edge, the major cause of poor tool life in threading. For Harder or more Abrasive Materials start in the Middle of the SFM range. Once setup is complete SFM can be adjusted for optimum tool life. Tough Micrograin Grade 310 reduces insert chipping from edge build-up at lower SFM and on parts under 1" Diameter.

Formulas to calculate **Revolutions Per Minute (RPM)** and **Surface Feet Per Minute (SFM)** :

$$RPM = SFM \times 12 \text{ Divided by Part Diameter} \times 3.1416$$

$$SFM = 3.1416 \times \text{Part Diameter, Divided by } 12 \times RPM$$

2. Use the G76 Threading Cycle with Fanuc, Yasnac and similar CNC controls.

If **P1, P2, P3, & P4** parameters are available, use **P1** for most applications. **G76 - P1** removes equal amounts of material with every pass. **P2** alternates between front & back cutting edges and should only be used on 6 tpi & coarser threads.

3. Set Depth of Cut for the First Pass at 20% to 30% of the Thread Height Per Side.

G76 controls the depth of cut for the remaining passes. To find the **DOC** for the 1st Pass multiply the **PITCH** by .6 to get the approximate **THREAD HEIGHT**. Multiply **THREAD HEIGHT** by 20 - 30% to get the **DEPTH** of the 1st Pass. Use less than 20% when threading hard materials or larger thread pitches. Don't use "Spring Passes" under .002 DOC Per Side!

Example for calculating the **DOC** for the first pass on a 1/2-20 thread:

$$1" \quad 20 = .050 \text{ PITCH}), (.050 \times .6 = .030 \text{ (THREAD HEIGHT)}, .030 \times .3 = .009 \text{ (DEPTH OF 1st PASS)}$$

4. Use the A55 Parameter to set the Infeed Angle.

Most CNC Lathe Controls offer a choice of **A60, A55, A30 & A29**. **A60** is the default setting. **A55** is equivalent to setting the compound feed on a manual lathe to 27.5°. In most applications **A55** will double or triple tool life over **A60**. See below:

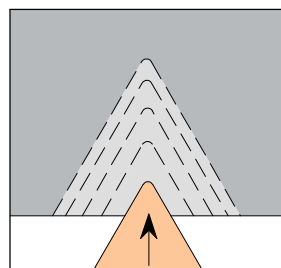

Radial Feed

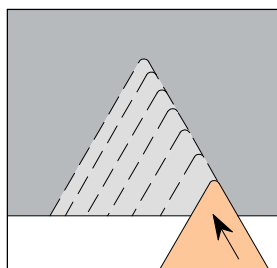

Flank Feed - A60

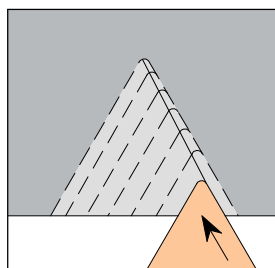

Mod. Flank Feed - A55

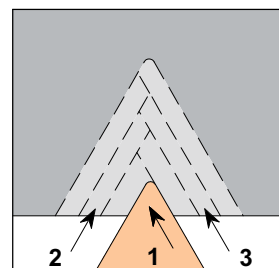

Alternating Feed - P2

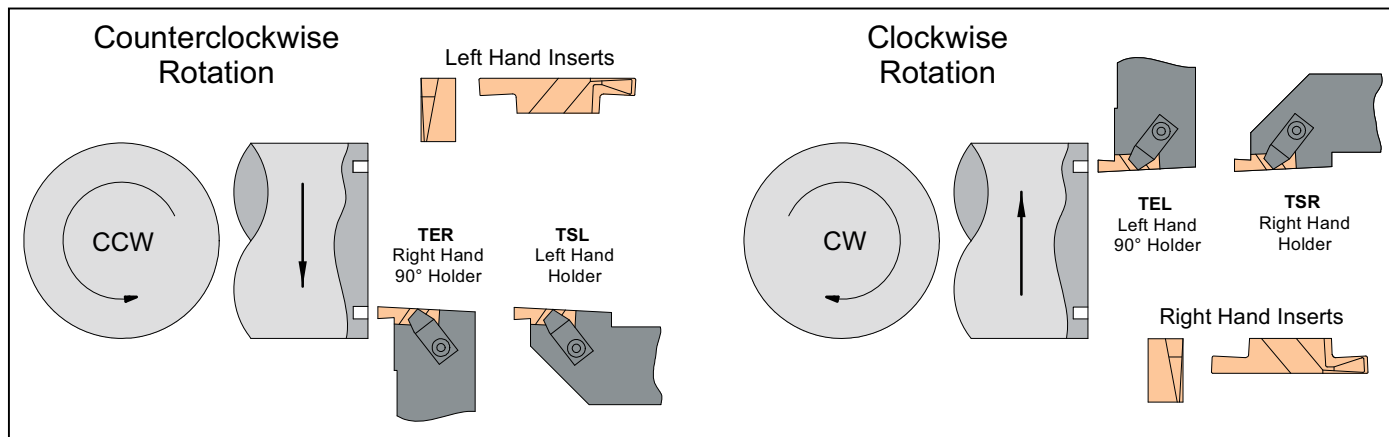

Counterclockwise Spindle Rotation is the recommended method for most face grooving applications

Horizon Face Grooving Inserts					
Specials	Standards	Insert	W	E - Max. Depth	Min. Groove Dia.
Chip Curler	<p>HF xxxxL</p>	HF 3062L or R	.062	.125	1.000
		HF 3072L or R	.072	.125	1.000
		HF 3094L or R	.094	.185	1.000
Full Nose Radius	<p>12° TO 18°</p>	HF 3098L or R	.098	.185	1.000
		HF 3110L or R	.110	.185	1.125
Knife Edge	<p>12°</p>	HF 3125L or R	.125	.185	1.125
Dovetail		HF 3156L or R	.156	.185	1.200
		HF 3189L or R	.189	.185	1.200
		HF 4250L or R	.250	.255	2.250
		HFD 3125L or R	.125	.250	1.875
		HFD 4189L or R	.189	.375	2.250
		HFD 4250L or R	.250	.500	2.250

TiALN Coated Micrograin Grade 310 is the 1st Choice for most Face Grooving applications. In Stainless and Softer Steels start at 300 SFM and .0005 to .002 Feed; Titanium, Inconel & other High Temp Alloys start at 100 - 150 SFM and .0005 to .0015 Feed. Use Uncoated Grade C23 for Aluminum, Copper and Plastics at higher Speeds and Feeds.

Standard Grooving Inserts can be used for Larger Diameter Face Grooving without Modification			
Insert	Insert Width	Maximum Groove Depth	Minimum Groove Diameter
HG 20xxL or R	Under .047	.055	2.125
HG 20xxL or R	.047 to .062	.080	2.750
HG 20xxL or R	.062 and up	.115	3.500
HG 30xxL or R	Under .047	.055	2.125
HG 30xxL or R	.047 to .062	.080	2.750
HG 30xxL or R	.062 to .094	.115	3.500
HG 30xxL or R	.094 to .125	.192	6.00
HG 31xxL or R	.125 and up	.205	6.500
HG 4125L or R	.125	.205	7.250
HG 4156L or R	.156	.205	7.250
HG 4189L or R	.189	.255	8.250
HG 4250L or R	.250	.255	8.250

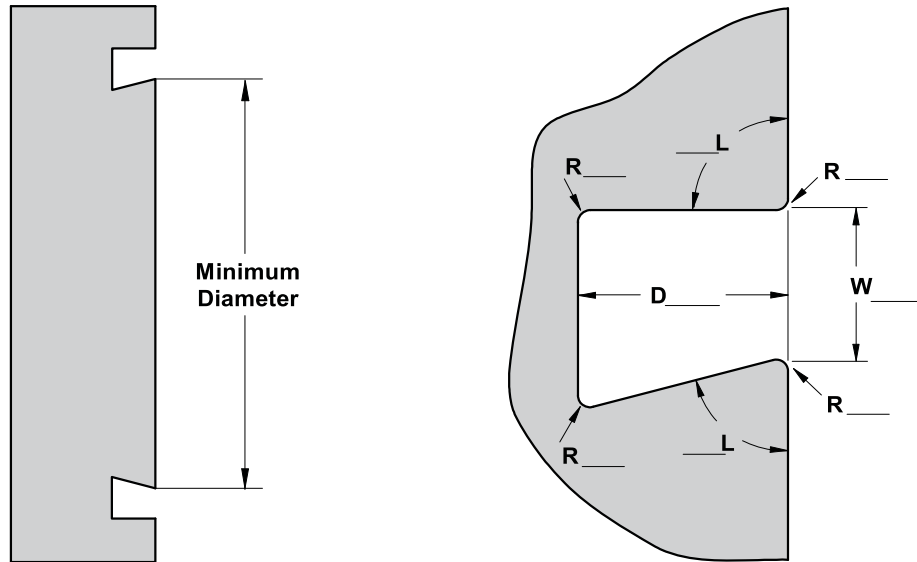
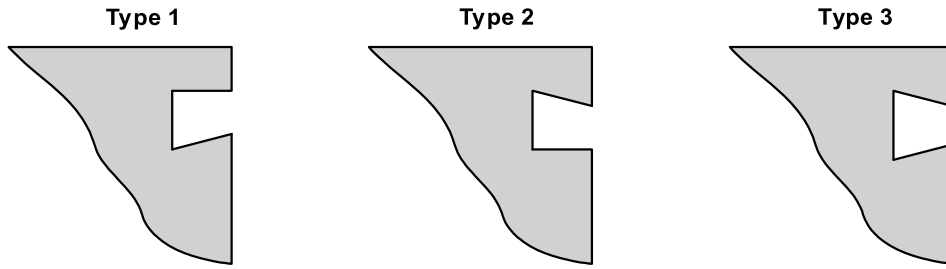

Left Hand Inserts for Counterclockwise Rotation

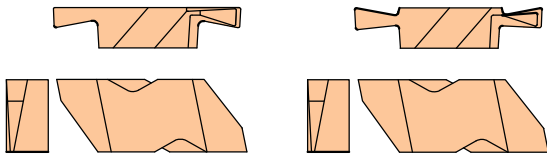

Right Hand Inserts for Clockwise Rotation

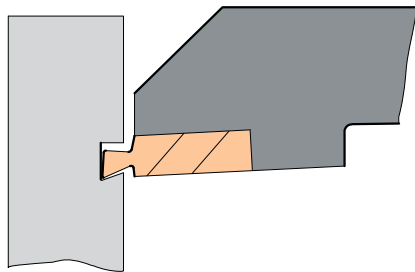
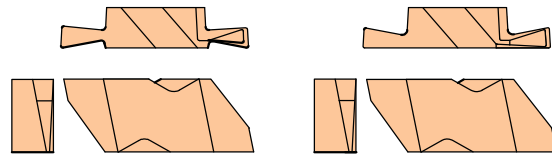

CORRECT
Ramp in with
Multiple Passes



WRONG
Can Result in
Insert Breakage



**Infeed for Dovetail
Face Grooving**

Dovetail Face Grooves are used in the High Vacuum and Hydraulic Industries to retain O-Ring Seals in Plates and Flanges. There is no Industry Standard for these types of grooves. Dovetail Grooving Inserts are made to Print. Horizon Stocks a number of Special Inserts in frequently used sizes. Call for availability.

TiALN Coated Grade 310 is the First Choice for Face Grooving tough materials. Start at 150 to 300 SFM with a Feed Rate of .0005 to .001 Per Rev. Ramp into the cut as shown above. For best results machine an entry groove with a Standard Face Grooving Insert the width of the top of the Dovetail Groove.

Horizon	Tool-Flo®	Kennametal®	RTW®	Valenite®	Sandvik® **	Mitsubishi®	Insert Style
Notch Style Grooving Inserts							
HF	FLF	NF	---	---	TLF	EF	Face Grooving
HFD	FLFD	NFD	---	---	---	EFD	Deep Face Grooving
HG	FLG	NG	PG	VLG	TLG	EG	ID or OD Grooving
HG RK-LK *	FLG CB *	NG RK-LK *	PG RK-LK *	---	---	EG RK-LK *	With Chipbreaker *
HGD	FLGD	NGD	PGD	---	---	EGD	Deep Grooving
HGD RK-LK	---	NGD RK-LK *	PGD RK-LK *	---	---	---	Deep Grooving Chipbrker *
HGP	FLGP	NGP	---	VLGP	TLGP	EGP	Positive Grooving
HP	---	NP	---	---	---	EP	Back Turning
HR	FLR	NR	PR	VLR	TLR	EGR	Full Nose Radius
HRP	FLRP	NRP	PRP	VLRP	TLRP	---	Positive Full Nose Radius
HU	FLU	NU	---	---	TLU	---	45° Undercutting
HV	FLV	NV	---	---	TLV	---	Poly-V 40°

Notch Style Threading Inserts							
HA	FLA	NA	PA	VLA	TLA	---	Acme
HAS	FLAS	NAS	PAS	VLAS	TLAS	---	Stub Acme
HDC	FLDC	NDC	PDC	VLDC	TLDC	---	NPT Full Profile
HJ	FLJ	NJ	---	---	TLJ	---	UNJ
HJF	FLJF	NJF	---	---	TLJF	---	UNJ Fine Pitch
HT	FLT	NT	PT	VLT	TLT	ET	60° V Partial Profile
HTB	FLTB	NTB	---	---	TLTB	---	American Buttress
HTC	FLTC	NTC	PTC	---	TLTC	---	60° V Full Profile Topping
HTF	FLTF	NTF	PTF	VLTF	TLTF	---	60° V Fine Pitch
HTK	FLTK	NTK	PTK	VLTK	TLTK	---	60° V Fine Pitch Positive
HTP	FLTP	NTP	PTP	VLTP	TLTP	---	60° V Positive

Notch Style Profiling Inserts							
DPGR	DPGR	DPGR	---	---	---	---	55° Profiling
HPL	FLPL	NPL	---	---	---	---	LH 55° Profiling
HPR	FLPR	NPR	---	---	---	---	RH 55° Profiling
VPGR	VPGR	VPGR	---	---	---	---	35° Profiling

* Horizon **RK-LK** Style Inserts have ground-in 15° to 18° positive rake "Chip Curlers" with sharp edges for free cutting action in tough materials. Competitive Grooving Inserts have molded chipbreakers designed for Steel. See page 41

** TopLock® style Inserts available on Special Order. Industry Standard Inserts fit Sandvik TL® holders by changing to Kennametal® style insert clamps. See Pages 31 - 33 for replacement clamps.

Horizon	Tool-Flo®	Kennametal®	RTW®	Vardex®	Sandvik®	SecoCarboloy®	Insert Style
Laydown Threading Inserts							
11NR	11NR	LT11-NR	11NR	2IR	R166.0I-11	11NR	1/4" IC RH INTERNAL
11NL	11NL	LT11-NL	11NL	2IL	L166.0I-11	11NL	1/4" IC LH INTERNAL
16ER	16ER	LT16-ER	16ER	3ER	---	16ER	3/8" IC RH EXTERNAL
16EL	16EL	LT16-EL	16EL	3EL	---	16EL	3/8" IC LH EXTERNAL
16NR	16NR	LT16-NR	16NR	3IR	---	16NR	3/8" IC RH INTERNAL
16NL	16NL	LT16-NL	16NL	3IL	---	16NL	3/8" IC LH INTERNAL
22ER	22ER	LT22-ER	22ER	4ER	---	22ER	1/2" IC RH EXTERNAL
22EL	22EL	LT22-EL	22EL	4EL	---	22EL	1/2" IC LH EXTERNAL
22NR	22NR	LT22-NR	22NR	4IR	---	22NR	1/2" IC RH INTERNAL
22NL	22NL	LT22-NL	22NL	4IL	---	22NL	1/2" IC LH INTERNAL
27ER	---	---	27ER	5ER	---	27ER	5/8" IC RH EXTERNAL
27EL	---	---	27EL	5EL	---	27EL	5/8" IC LH EXTERNAL
27NR	---	---	27NR	5IR	---	27NR	5/8" IC RH INTERNAL
27NL	---	---	27NL	5IL	---	27NL	5/8" IC LH INTERNAL

HORIZON RK - LK "CHIP CURLER" GROOVING INSERTS



15° to 18° Positive Rakes Lower Cutting Forces and Reduce Built-Up Edge Problems

Sharp Cutting Edges for Tough, Gummy Materials like Stainless, Titanium and Inconel®

Free Cutting Action - Great for Small Diameters and Thin Walled Parts

Uncoated Inserts for Aluminum and Plastics have Polished Chip Curlers

Available in Standard Depth, Deep Depth and Face Grooving Inserts

Chip Curler Inserts

Standard Inserts

Competitive Chipbreaker Inserts

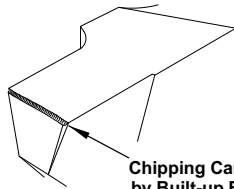
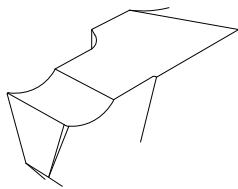

Chipping Caused by Built-up Edge

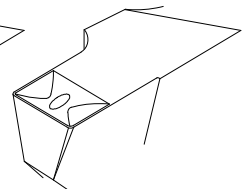
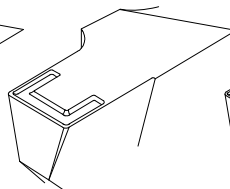
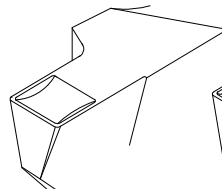

Horizon Precision Ground "Chip Curler" Inserts prevent Edge Built-up in tough, gummy materials. Sharp, positive rake edges lower cutting forces providing easy chip flow.

Recommended Feeds for tough materials - .0005 to .003 IPR. Softer Materials can be machined at higher feeds. Uncoated Inserts for Aluminum and Plastic have polished rakes.

Molded Chipbreaker Inserts are designed for machining Medium to High Carbon Steels at feed rates over .005 per rev. Most of these Inserts have a .003 to .010 wide land in front of the chipbreaker.

The area of chip contact rarely exceeds the land width at feeds under .005 IPR. At lighter feed rates performance difference is minimal between chipbreaker Inserts and standard flat top styles.

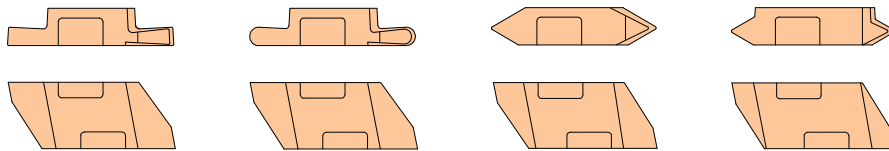

Threading and Grooving Inserts are available with TL® Style Notches on Special Order

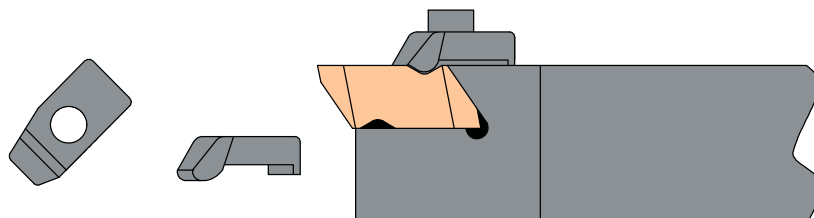

Changing Clamps allows the use of Industry Standard Inserts in TL® Holders - See pages 31 - 33

GRADE COMPARISONS

48

Horizon	Tool-Flo®	Kennametal®	Valenite®	Sandvik®	Carboloy®	RTW®	Applications
Uncoated Grades							
C10	GFI C22	K6	VC101	S6 (Low SFM)	---	CQ22	Tough Grades for low SFM in most materials. Good for interrupted cuts.
C20	C22 C25	K6 K68	VC2	H13A	883 HX	CQ2	General Purpose C2 Grades for Non-ferrous materials and Cast Iron .
C23 C23J	C25 C3	K68 K313	VC2 VC29	H10A H13A	883 890 HX	CQ2 CQ23	C2-C3 Grades for Non-ferrous materials such as Aluminum Copper & Plastic.
C56	C56H C6H	K420	VC5 VC56	S6	350 370 S25M	CY16	C5-C6 Grades for Carbon & Alloy Steels.
HCC	MP3 MP6	KT175	VC67	GC525	---	---	C7-C8 Ceramet Grades for high speed finishing in Steels.
PVD Coated Grades							
310FG	G4, GP4	KC720 KC5025	V1N VC901	---	CP50	---	Tough Coated C1 / C5 Grades for low SFM in most materials.
320AP	---	---	---	---	---	---	Highwear Resistant Grade Cast Iron Grey Ductile
323FG	GP22 GP25 GP3	KC730	VC901 VC929	1015 1025	CP30 CP50	R321	Coated C2-C3 Non-ferrous Grades. Also for light cuts in Steel & Stainless.
356FG	GP50 GP5 GP6	KC710	SV230 VN5 VN7	1025 225 2135	CP30	716 621	Coated C5-C6 Grades for Carbon & Alloy Steels.
310	AP22 AP25 AP3	KC720 KC5025	VC901 V1N	2135 225	CP50 CP200	---	Tough coated C1-C2 / C5 Grades for a wide range of materials at moderate speeds and feeds.
323	AP22 AP25 AP3 GP25 GP3	KC730 KC732 KC5010 KC5025 KC7310	VC901 VC929	1005 1015 1025 3020	CP50 CP200	R323	Coated C2-C3 / C6-C7 Grades for 300 Series Stainless, High Temp Alloys & Titanium.
323F	AP22 AP25 AP3 GP25 GP3	KC730 KC732 KC5010 KC5025 KC7310	VC901 VC929	1005 1015 1025 3020	CP30 - CP50 CP200	R323	Coated C2-C3 / C6-C7 Grades for 300 Series Stainless, High Temp Alloys & Titanium.
323G	AP22 AP25 AP3 GP25 GP3	KC730 KC732 KC5010 KC5025 KC7310	VC901 VC929	1005 1015 1025 3020	CP50 CP200	R323	Coated C2-C3 / C6-C7 Grades for 300 Series Stainless, High Temp Alloys & Titanium.
356	AP50 AP5 AP6	KC710 KC810 KC850 KC5025	SV210 VN7 SV230	1015 1025 225 2135	CP50	716	Coated C5-C6 Grades For Carbon & Alloy Steels plus 400 Series Stainless Steels.
CVD Coated Grades							
423	G22	KC732	V1N VN2 SV210	1015 1025 3020	---	027	CVD TIN coated C2-C3 / C7 Grades. For Non-Ferrous use & light cuts in Steel & Stainless.
456	G5 G53 G54	KC810 KC850	SV230	1025 225 2135	550	716 RC706	CVD TIN coated C5-C6 Grades for Carbon & Alloy Steels.
556	G53 G6	KC810 KC850 KC935	SV210 SV230	225 2135 4125	560 570	716 918 925 RC706 RC906	CVD Coated C5-C6-C7 Grades for Steels & Stainless at medium to high speeds.
<p>These are <u>Approximate</u> Grade Conversions. Bold Type = Standard Horizon Grades and Competitive Equivalents. For Best Results Please Call Horizon Carbide Tool for Grade Recommendations. See Page 4 for More Information on Horizon Carbide Grades</p>							

Insert Heat and Wear Zones

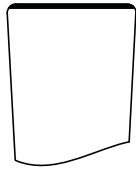

Grooving

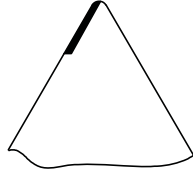

Threading & Finishing

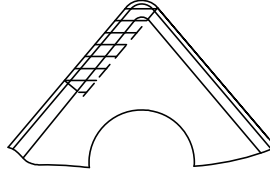

Roughing

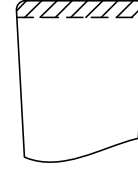

Steel Grooving

Feeds .0005 to .003 IPR

¹(Group 10 and 23 Grades)

Feed Rates over .005 IPR

²(Group 56 Grades)

¹ Threading, Grooving and Finishing operations generate considerable heat at the cutting edge. The Inserts often cut through abrasive, work hardened surfaces. Carbide Grades for these applications need to have high heat and wear resistant edges.

² Steel Cutting Inserts have to absorb and dissipate the large volume of heat that develops behind the cutting edge where the chips start to curl. Cratering can occur in this area due to high cutting forces. Steel Grades have additives and/or coatings to provide crater resistance. These Grades generally have less heat and wear resistant cutting edges than the Grades used in finishing applications. The edges on Steel Cutting Inserts are usually honed to prevent chipping.

PRIMARY GRADES 1st choice for best results			
Carbide Groups	Uncoated	TIN Coated	TiALN Coated Applications
10 Tough, Chip Resistant C1 Micrograin Grades	C10	310FG	310 C10 C1 - High wear & chip resistance at very low speeds in most materials
			310FG C1-C2/C5 - Increased tool life, reduced chipping from built-up edge
			310 C1-C2/C5 - Face Grooving - Small Diameter Threading and Grooving
23 Heat & Wear Resistant C2-C3 Micrograin Grades	C23	323FG	323 C2-C3 - Non-Ferrous applications - C23J has polished chipbreakers
			323FG C2-C3/C6-TIN coating adds lubricity reducing edge build-up & chipping
			323 C2-C3/C7 - Heat & wear resistance in Threading, Grooving & Finishing
56 C5-C6 Crater Resistant Steel Cutting Grades	C56 non stock	356FG	356 C5-C6 - Uncoated Special Order only - use coated Grades 356 or 156
			356FG C5-C6 - For use where edge build-up is a problem with Grade 356
			356 C5-C6 - Steel Cutting Grade - moderate speeds, higher feeds than 323
For specific applications			
320AP	-	-	- Aloxide Coating for Cast Iron
Horizon Carbide - Standard Grade Application Ranges			
Wear Resistant Grades for Cast Iron and Non-Ferrous Materials plus Threading, Grooving and Finishing Applications			
	C2 (K25)		C3 (K15 - K10)
	323 - 323F - 323G		
		323FG	
		C23 - C23J	
310 Threading & Grooving			
310FG Threading & Grooving			
C10 Threading & Grooving			
		HCC Ceramet - Special Order	
← Increasing Toughness - Shock & Impact Resistance		Increasing Hardness - Heat & Wear Resistance →	
Crater Resistant Grades for Steel & Stainless plus Wear Resistant Grades for Threading, Grooving and Finishing			
C5 (P50 - P35)		C6 (P30 - P20)	
		323 - 323F - 323FG Threading, Grooving & Finishing	
		323FG Threading & Grooving	
		356	
		356FG	
310 Threading & Grooving			
310FG Threading & Grooving			
		HCC Ceramet - Special Order	

Cutting Edge Height vs. Insert Thickness

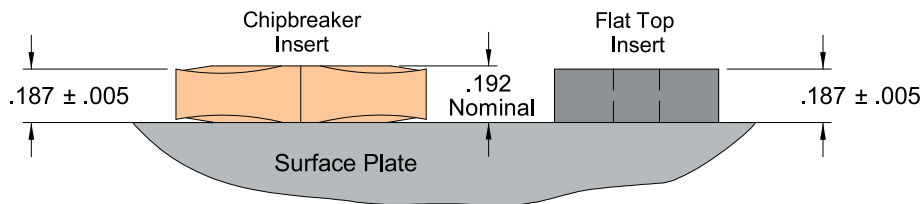

The Industry Standard thickness tolerance for “G” (ground) and “M” (molded) class Inserts is $\pm .005$. This standard was established before the introduction of molded chipbreakers and creates confusion regarding double sided turning Inserts.

Negative rake chipbreaker Inserts are nominally thicker than flat top Inserts. An elevated pad on both sides of the Inserts keep the unused edges from contacting the tool holder or shim seat. The tolerance refers to the cutting edge height rather than the Insert thickness. The easiest way to measure the cutting edge height is with a height gage on a surface plate.

Tool Holder Insert Height

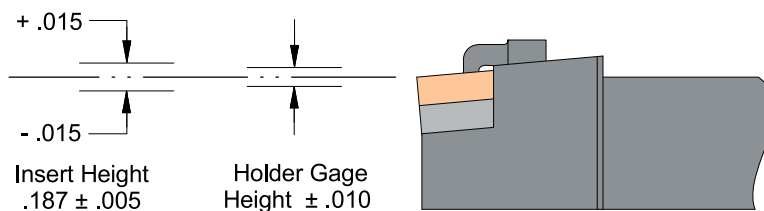

The Industry Standard for Insert height in tool holders is $\pm .010$. This creates a Center Height range of $.030 (\pm .015)$ when combined with the Insert tolerance of $\pm .005$. For best results on smaller diameter parts and/or small nose radius Inserts the center height should be adjusted to a maximum of $\pm .001$.

Insert Cutting Edge Height

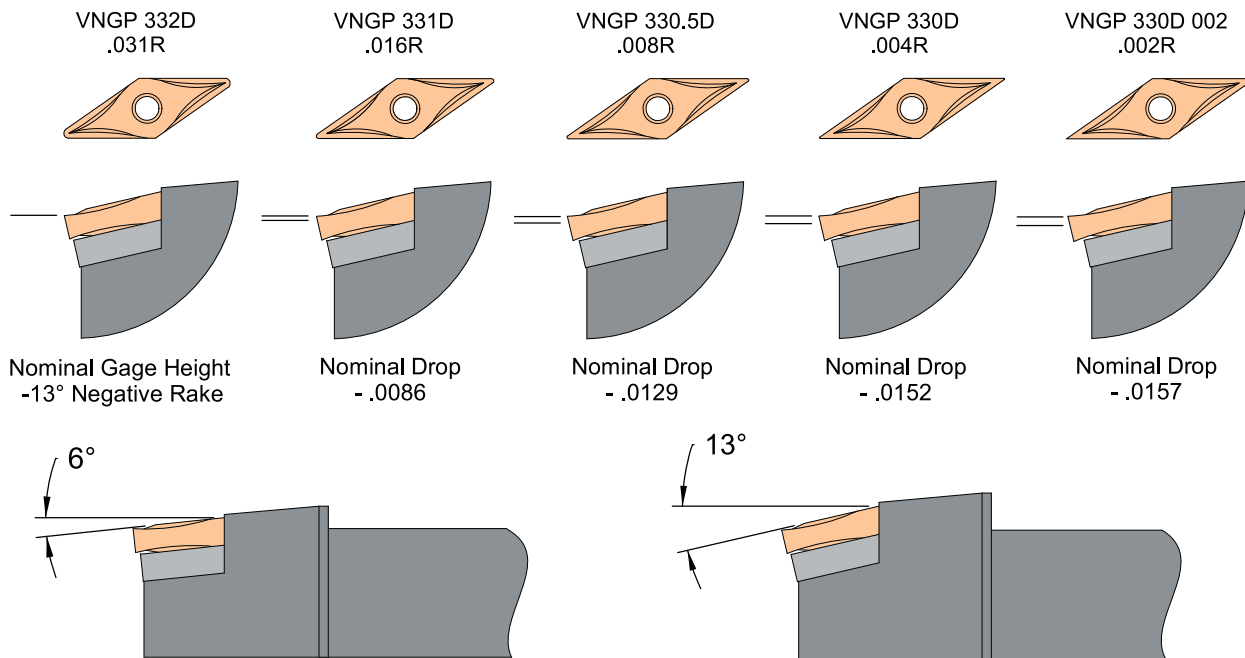

Insert heights for most negative rake tool holders are set using $.031R$ Gage Inserts. There are no geometry standards for negative rake 35° tool holders. Insert rake angles vary between manufacturers and range from -6° to -13° . This causes problems with inserts having a nose radius other than $.031R$. Center Heights for smaller radius inserts drop due to the negative rake angles. The drop is significant with 35° and 55° Negative Rake inserts. Horizon DNGP and VNGP Inserts are ground to the low side of the height tolerance to reduce center height problems.

Chip Formation

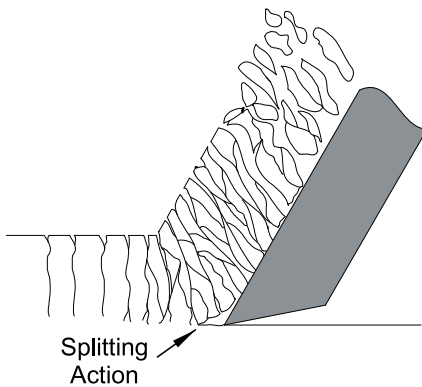

Cast Iron, Hard Brass and other materials that produce powdery chips

Chips begin breaking in front of the cutting edge. Chip controls is usually not a problem. Harder, more heat and wear resistant carbide grades such as 323 or 323F work well on these applications. Use sharp inserts for most Non-Ferrous materials. Most Cast Iron Inserts are honed to resist chipping. Abrasive flank wear is the primary failure mode.

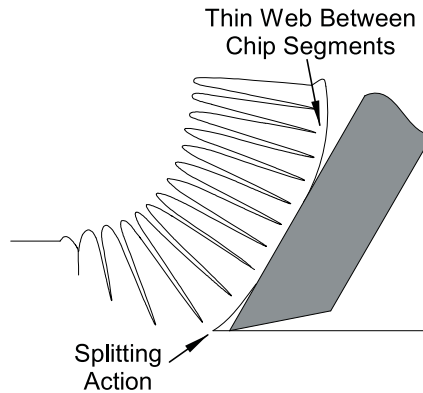

Carbon and Alloys Steels with Medium to High Carbon Content

1035, 1045, 1144, 4130, 4140, 4340 Carbon and Alloy Steels that contain at least .3% Carbon are hardenable by heating and quenching. The cutting action is similar to a wedge splitting wood. High pressure develops in the zone behind the cutting edge where chips start to curl. Cratering can occur in this area. Steel cutting grades and coatings help eliminate this problem.

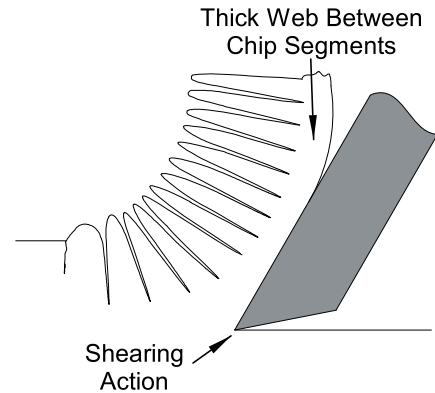

Low Carbon Steels, Stainless, Nickel Alloys, Titanium, Aluminum & Copper

Tough, gummy metals that need to be sheared. Chips are thicker and more difficult to break than those produced at the same feeds in Steel. Chip welding and edge build-up is a common problem in these materials. Sharp Inserts with positive rake chipbreakers work well in these applications. Horizon RK/LK style Grooving Inserts are recommended.

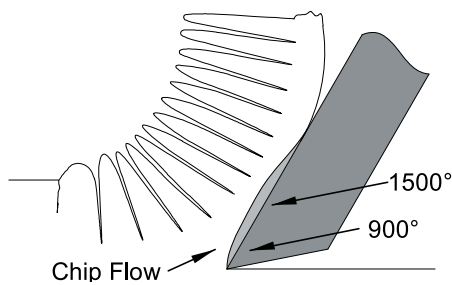

Under optimum cutting conditions, the underside of the chips soften to become almost fluid as they pass across the Insert. This helps chips flow easily out of the cut. The flow zone behind the cutting edge is where the highest heat and pressure develops. Cratering can also occur in this area.

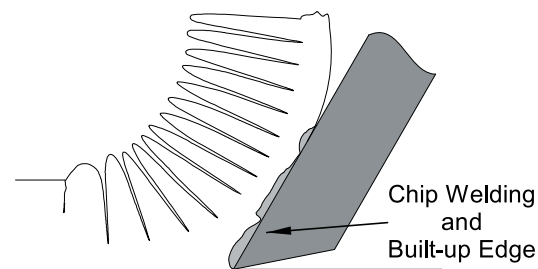

Built-up edge occurs when the SFM is too low to generate enough heat to keep chips from pressure welding to the Insert. This results in poor finish and edge chipping. Increased SFM, positive rake geometry and coated Inserts reduce chip welding. Use grades 110 or 310 to resist chipping when the SFM can not be sufficiently increased.

A .002 to .003 wide area of chipping or cratering across the top face of a grooving Insert is usually an indication of edge build-up. In most instances increasing the SFM will correct the problem. Also check to insure that the tool is not running above center. Horizon RK / LK Chip Curler inserts help prevent build-up in tough, gummy materials.

.002 -.003 Chipping or Cratering at the Cutting Edge

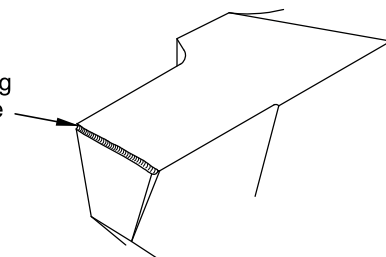

FAST DELIVERY ON SPECIALS!

Modified and Full Special Carbide Insert Tooling

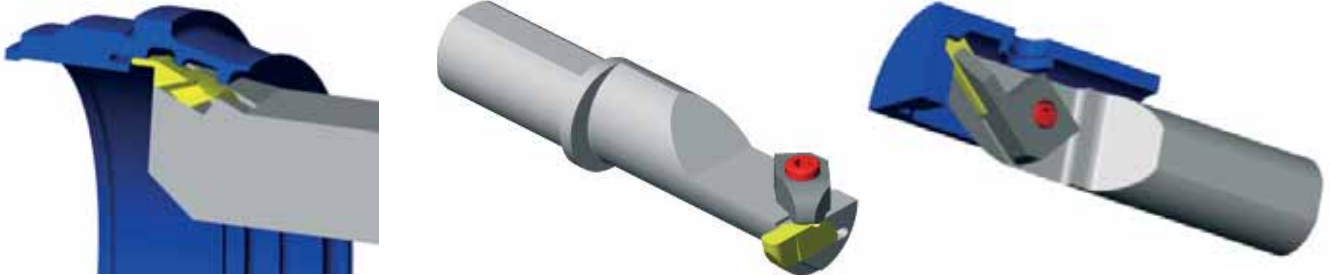

1. ***SolidWorks® 3D CAD Software used for Special Tooling Design and Engineering.***
2. ***For Fast Quotes send your Drawings, Part Prints, SolidWorks or DXF/DWG CAD Files.***
3. ***Close Tolerance CNC Grinding for fast, accurate precision ground Specials Inserts.***
4. ***Standard Tolerance for Special Inserts $\pm .0005$ - Closer Tolerances on request.***
5. ***Only Premium Quality Carbide Blanks are used. A large Inventory is kept in Stock.***
6. ***Special Inserts can be supplied with any Commercially available coating process.***

SolidWorks

Manufacturing
Network
Partner

→ **e DRAWINGS***

See our web site for details: www.horizoncarbide.com

We Regrind Ceramic Inserts

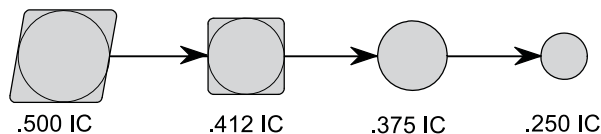

***New or Used Ceramic Inserts Reground, Reshaped or Downsized.
Get the maximum use out of expensive Ceramic Inserts.
Our Standard Regrind Tolerance is $\pm .0005$***

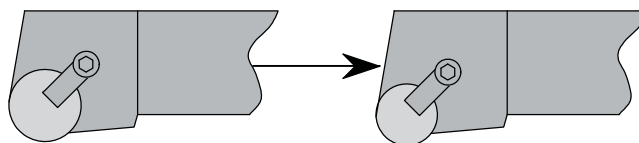

We can provide Special Tool Holders for Resized Ceramic Inserts.

***Horizon Specializes in Grinding Whisker Reinforced and other High Tech Ceramic Materials.
50 Piece Min. Quantity for Regrinding Used Ceramic Inserts. Call for additional information.***

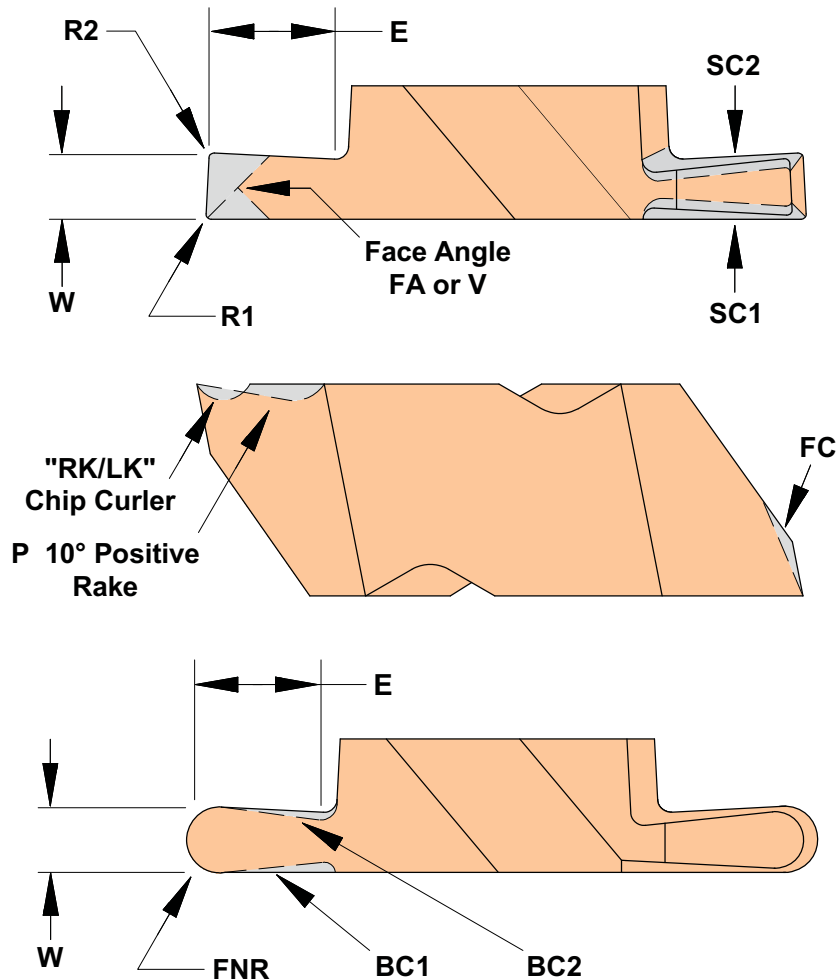

Quick Modifications Guide for Standard Threading and Grooving Inserts

E - Back Distance or Maximum Depth of Cut

W - Width of Cut

R1 - Outer Corner Radius *

R2 - Inner Corner Radius *

FNR - Full Nose Radius **

RK/LK - 10°- 20° Chip Curler - RH or LH Inserts **

P - 10° Positive Rake - Standard Rake is 5° **

FA - Face Angle **

V - Threading or Grooving Angle **

FC - Increased Face Clearance Angle

SC1 - Outer Side Clearance Angle

SC2 - Inner Side Clearance Angle

BC1 - Outer Back Clearance Angle *

BC2 - Inner Back Clearance Angle *

* Width of Cut may change with modifications

** Width and/or Depth of Cut may change with modifications

Uncoated Inserts modified in 1 to 3 Working Days - Please add 3 to 10 Days for Coatings.

Horizon can provide inserts with any commercially available coating. Some coated Inserts can be re-coated after modification: PVD TIN can be re-coated with TIN, TiCN or TiALN coatings: TiALN coated Inserts can be re-coated with PVD TIN. Note: PVD re-coating can chip or flake off due to excess coating thickness. Performance is not guaranteed on recoated inserts.

Some Insert modifications don't require re-coating. Aside from cosmetics, the removal of PVD coating from the periphery of a Carbide Insert has minimal effect on its performance in most applications so long as the coating on the Top Surface of the Insert remains intact.

Please Contact Horizon Carbide Tool for Price and Delivery on Modified Standard Inserts

SPECIAL TOOLING REQUEST FORM

Fax or Send Request to:



2404 S. Industrial Park Ave. Tempe, AZ 85282
(480) 968-0957 Fax (480) 968-8042
E-mail info@horizoncarbide.com

Date _____ Page ____ Of ____
Company Name _____ Phone _____
Contact _____ Fax _____
Address _____ Pager or VM _____
City _____ State ____ Zip _____ E-mail _____
Horizon Distributor _____ Contact _____

Machine Information

Turning ____ Milling ____ Machine Make & Model _____
Age & Condition _____ HP ____ Max RPM _____ Max Table Feed - IPM _____
Limitations _____ Coolant - Dry ____ Wet ____ Type _____
Fixturing / Workholding _____
Additional Information _____

Part Information

Description _____
Material _____ Condition _____
Hardness (Rc) _____ Tolerance _____ Surface Finish Requirements _____

Tool Information

Tool Description _____
Shank Size / Description _____ Right or Left Hand Cutting _____
Current Tooling _____
Special Tool Holder Requirements _____ Quantities to be Quoted _____
Current Problem or Objective _____



Please Attach Drawings of Your Parts and Special Tooling.
You can also E-mail us SolidWorks or DXF-DWG CAD Files.

Thread Milling Programming Services

Copy this form, fill in the information then **fax it to: 1-800-968-8042**

Contact Us At: 1-800-968-0957

Programming Request Form

Company Name: _____ Date: ____/____/____
Contact: _____ Telephone: (____) _____
Tooling Purchased From: _____ Fax Number: (____) _____

Machine Information:

Brand Make: _____
Model: _____
Spindle Taper: 35 Cat 40 Cat 50 Cat
Max RPM: _____

CNC Controller Information:

Brand Make: _____
Model: _____
ISO - ASCII Compatible: Yes No Don't Know
Is Helical Option Available: Yes No Don't Know

Thread Specification To Be Produced:

Thread Specification: _____
Length Of Full Thread: _____
Thread Form: 100% 75% Other _____%
Thread: Internal External
Drill Size: _____" Thru Blind Counterbored

Material To Be Machined:

Material: _____
Hardness: _____
Condition: Annealed Normalized Heat Treated
 Cast Forged Rolled Plate Bar
 Pre-Machined Flame Cut Scale Sand

Thread Mill Selected:

Solid Carbide Indexable

Tool Description: _____

Insert Selected (If Indexable): _____

If you are not sure what tool to select, check one of the following and we will recommend a tool for you:

Shortest Cycle Time Lowest Tooling Cost

Tool Recommended: _____

Programming Data:

Dimensions: Inch Metric

Program Values: Absolute (G90) Incremental (G91)

Arc Center: I & J R (Radius)

Tool Path: Offset No Offset

Arc Limitation: Full Circle Quadrant

K Value: Not Required Required

If Required: In Radians Per Revolution

Feed Direction: Climb Mill Conventional

Note: Climb Milling is always recommended for carbide tooling. In some cases where thin wall parts, long extensions or worn spindle bearings are encountered, conventional milling may be an option to produce a given thread.

Thread Milling Speeds And Feeds

Formula To Determine RPM:

Formula To Determine Surface Feet Per Minute:

$$\text{RPM} = \frac{3.82 \times \text{SFPM}}{\text{Tool Cutter Diameter}}$$

$$\text{SFPM} = .262 \times \text{RPM} \times \text{Cutter Diameter}$$

Material To Be Thread Milled			Tool Shank Diameter & Number of Flutes							
			Starting SFPM & Suggested Feed In Inches Per Flute							
			1/8"	3/16"	1/4"	5/16"	3/8"	1/2"	3/4"	
Material Group	Classification	Typical Grades	3	3	5	5	5	5	5	6
1. - Steel	Plain Carbon & Low Carbon up to 22Rc	AISI/SAE Types: 1005-1020, 1108-1119, 1213-1215, 1513-1518 4012, 5015, 9310	600 .0003"	600 .0003"	600 .0005"	600 .0006"	600 .0007"	600 .001"	600 .0015"	600 .0015"
2. - Medium Carbon & Alloy Steels	Heat Treatable Carbon & Alloys From 22 to 32Rc	AISI/SAE Types: 1025-1095, 1130-1151, 1330-1345, 1520-1572, 4023-4063, 4120-4161 4320-4340, 4620-4640, 8620-8660, 8720-8750, 6150, 51000, 52100	575 .0003"	575 .0003"	575 .0005"	575 .0006"	575 .0007"	575 .001"	575 .0015"	575 .0015"
3. - Medium Carbon & Alloy Steels	Heat treatable Carbon & Alloys From 32 to 42Rc	AISI/SAE Types: 1040-1095, 1140-1151, 1330-1345, 1520-1572, 4023-4063, 4120-4161, 4330-4340, 4620-4640, 8620-8660, 8740-8750, 6150, 51000, 52100	525 .0003"	525 .0003"	525 .0005"	525 .0006"	525 .0007"	525 .001"	525 .0015"	525 .0015"
4. - Stainless Steels	Austenitic Stainless Steels	Types: 301-304, 310, 316, 321, 347	525 .0003"	525 .0003"	525 .0005"	525 .0006"	525 .0007"	525 .001"	525 .0015"	525 .0015"
5. - Stainless Steels	Martensitic Stainless Steels	Types: 403, 410, 416, 420, 430, 431, 440C	550 .0003"	550 .0003"	550 .0005"	550 .0006"	550 .0007"	550 .0008"	550 .0015"	550 .0015"
6. - Stainless Steels	Precipitation Hardening Stainless Steels	Types: 15-5PH, 17-4PH, AM350, AM355, AM363 PH13-8Mo, PH14-8Mo	300 .0003"	300 .0003"	300 .0005"	300 .0006"	300 .0007"	300 .0008"	300 .001"	300 .001"
7. - Nickel	Nickel & Nickel Base Alloys	Inconel 700, 713C, 718, Inconel X, Monel 400, 401, 404 & K, Rene 41, Rene 95, Waspaloy, Udimet 500 & 700	120 .0003"	120 .0003"	120 .0005"	120 .0006"	120 .0007"	120 .0008"	120 .001"	120 .001"
8. - Titanium	Titanium & Titanium Alloys	Commercially Pure Ti, Ti-6Al-4V, Ti-8Al-1Mo, Ti-7Al-4Mo	100 .0003"	100 .0003"	100 .0005"	100 .0006"	100 .0007"	100 .0007"	100 .0007"	100 .0007"
9. - Cast Iron	Gray, Malleable. Ductile (nodular)	ASTM A48, A220, A436 A319, A536, A602, SAE J158, SAE J434	600 .0003"	600 .0003"	600 .0006"	600 .0007"	600 .0008"	600 .001"	600 .0015"	600 .0015"
10. - Non Ferrous	Wrought & Low Si Cast Aluminum	6061, Free Machining Brass	1,700 .0003"	1,700 .0003"	1,700 .0006"	1,700 .0007"	1,700 .0008"	1,700 .001"	1,700 .0015"	1,700 .0015"